

GENERAL PURPOSE ENGINE

GXV50

PARTS CATALOGUE

5

FOREWORD INDEX

1

ENGINE GROUP

2

PART NUMBER INDEX

3

PART NAME INDEX

4

Instruction for use of parts catalogue

- **This parts catalogue was prepared based on the latest information available as of June 20, 2004.**
- See the parts catalogue news for any revision that is made after June 20, 2004.
- **Always specify the part number when ordering a part.**
- Check the model, type, serial numbers, color, maker, and the size as needed before ordering a part.
- Note that the illustrations (part drawings) can differ from the actual parts in shape. They are given just to help you to refer to the parts.
- **When modifications or additions to this parts catalogue are made, a revised edition will be issued at an appropriate time, with successively progressing revision numbers on the cover. We recommend obtaining such revisions in order to keep your parts catalogue up-to-date at all times. To check whether a parts catalogue revision has been issued, please contact your Honda distributor.**

Initial version issue date **June 20, 2004**
Honda Motor Co., Ltd.

CONTENTS

	Page	Address No.	
● How to refer to the part information	2	B 2	1
● Part catalogue structure	3	B 3	
● When the parts were revised	4	B 4	
● Abbreviations used in the parts catalogue.....	4	B 4	
● How to check the part block and serial numbers.....	5	B 5	
● Models, parts catalogue codes and applicable serial numbers	6	B 6	
● Features of each type.....	8	B 8	
● Fuel hose, general purpose hoses and vinyl hose.....	9	B 9	
● Illustrated index	10	B10	
● ENGINE GROUP.....	12	C 1	2
● PART NO. INDEX.....	33	E 1	3
● PART NAME INDEX.....	34	F 1	4



How to refer to the part information

A Reference with "Illustrated index"

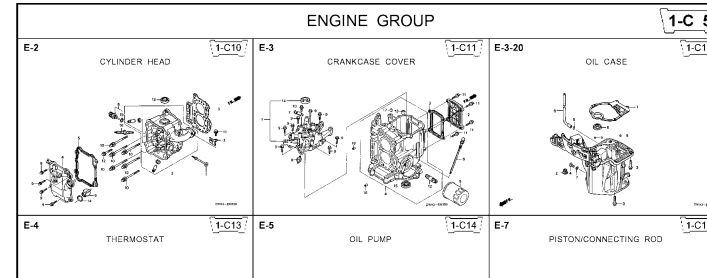

B Reference with "Part number index"

PART NO. INDEX

Part Number	Address	Page	Ref.	Part Number	Address	Page
06000				15212-ZW9-000	1-C14	3C
06316-ZW9-000	1-G9	88	1	15220-ZW9-003	1-C14	3C
11000				15332-ZW9-000	1-E8	55
11300-ZW9-405	1-C11	27	1	15332-ZW9-A30	1-E11	5E
11300-ZW9-406	1-C11	27	1	15400-PFB-004	1-C11	27
11340-ZW9-000	1-C11	27	2	15422-ZW9-000	1-C14	3C
11342-ZW9-000	1-C11	27	3	15473-881-000	1-C14	3C
11381-ZW9-003	1-C12	28	1	15474-ZW9-000	1-C14	3C
				15611-921-000	1-C10	2E
				15655-ZW9-000	1-C11	27
				16000		
12000				16010-ZV4-005	1-D4	3E
12000-ZW9-405ZA	1-C11	27	4	16011-ZV4-005	1-D4	3E
12155-ZV4-A00	1-C13	29	1	16013-ZW9-003	1-D4	3E
12166-ZW9-000	1-C10	26	1	16016-ZW9-003	1-D4	3E
12209-GB4-681	1-C16	32	1	16016-ZW9-721	1-D4	3E
12210-ZW9-405ZA	1-C10	26	2	16023-ZW9-003	1-D4	3E
12216-ZE2-300	1-E8	55	1	16024-ZV4-650	1-D4	3E
	1-E11	58	1	16028-ZV4-650	1-D4	3E

C Reference with "Part name index"

PART NAME INDEX

Part name	Address	Page	Ref.
[A]			
ABSORBER , FUEL	1-E15	62	5
ARMATURE COMP.	1-D11	43	7
ARM COMP. , LINK JOINT	1-G6	85	18
ARM COMP. , SHIFT LINK	1-G6	85	14
ARM COMP. , TILT	1-F15	79	20
ARM , FUEL PUMP ROCKER	1-C16	32	4
ARM , REVERSE LOCK	1-F15	79	18
ARM , SHIFT LINK	1-F11	74	7
ARM , STOPPER	1-D1	33	12
ARM , THROTTLE REMOTE	1-F11	74	6
ARM , VALVE ROCKER	1-C16	32	3
[B]			
BAG , TOOL , 160MM	1-G5	84	10
BAND	1-G6	86	37
BAND B1 , WIRE	1-F6	69	1
BAND , CORD	1-F3	67	18
BAND , TUBE CLIP , 11MM	1-E15	63	20
BAND , TUBE CLIP , 12.5MM	1-E15	63	19

Address No. 1-C10

E-2 CYLINDER HEAD

Block No.

Ref No.

Ref. No.	Part No.	Description	Reqd. QTY						Serial No.	Parts catalogue code
			9901	9901	1001	1001	1001	1001		
1	12166-ZW9-000	STOPPER, ENGINE SIDE	2	2	2	2	2			
2	12210-ZW9-000ZA	HEAD COMP., CYLINDER	1	1	1	1	1			
3	12251-ZW9-003	GASKET, CYLINDER HEAD	1	1	1	1	1			
4	12310-ZW9-000	COVER COMP., HEAD	1	1	1	1	1			
5	12312-ZW9-000	PACKINGS, HEAD COVER	1	1	1	1	1			
6	15611-921-000	CAP, OIL (NO GAUGE)	1	1	1	1	1			
7	16617-ZW9-000	HOLDER, CABLE	1	1	1	1	1	SC,SG		
	16617-ZW9-010		1	1	1	1	1	1001800	LHC,LHD	
			1	1	1	1	1	1001801	LHC,LHD	
8	35673-ZW5-003	SENSOR ASSY., WATER	1	1	1	1	1			
9	90003-ZW9-000	BOLT, FLANGE, 6X22	4	4	4	4	4			
10	90007-ZW9-003	BOLT, FLANGE, 8X83	6	6	6	6	6			
11	90011-ZW9-000	BOLT, FLANGE, 6X14(CT200)	1	1	1	1	1			
12	90020-ZW9-000	BOLT, FLANGE, 8X40	2	2	2	2	2			
13	91002-K19-003	OIL SEAL, 20X32X6	1	1	1	1	1			
14	91301-805-000	O-RING, 26X2.7	1	1	1	1	1			
15	91307-PK2-005	O-RING, 9.5X1.5(HONDA KIKAKI)	1	1	1	1	1			
16	98059-55916	PLUG, SPARK (CR5EH-9)	2	2	2	2	2			
	98059-55926	PLUG, SPARK (U16FER9)	2	2	2	2	2			

Service item F.R.T.

- O-RING, 26X2.7 0.1
- PLUG, SPARK 0.2
- O-RING, 9.5X1.5 0.2
- SENSOR ASSY., WATER TEMPERATURE 0.3
- COVER COMP., HEAD 0.3
- PACKING, HEAD COVER 1.8
- GASKET, CYLINDER HEAD 2.4
- OIL SEAL, 20X32X6 2.4
- HEAD COMP., CYLINDER 3.1

ZW83-ED200

Page No. 2000.09.20 E

Part catalogue structure

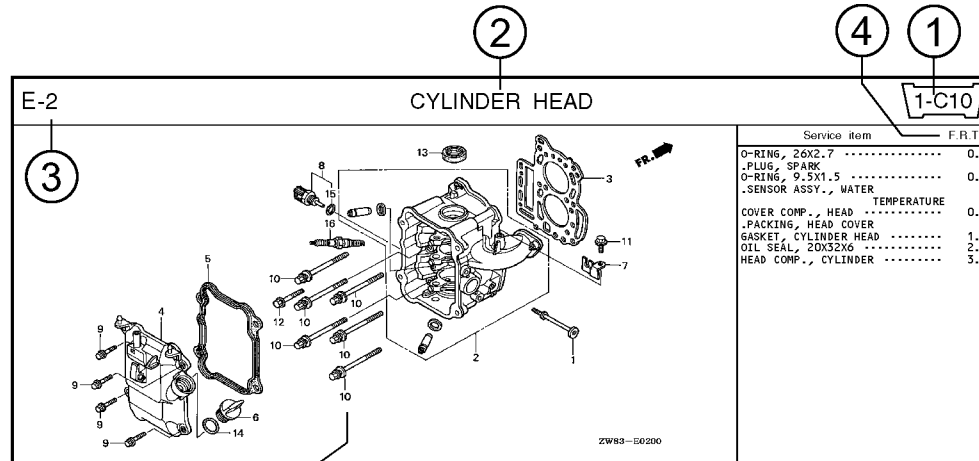

Ref. No.	Part No.	Description	Reqd. QTY						Serial No.	Parts catalogue code
			BF 9/9D1	BFP 10D1	BF 10D1	BFP 10B1	BF 10B1	BFP 10B1		
1	12166-zw9-000	STOPPER, ENGINE SIDE	2	2	2	2	2			
2	12210-zw9-000ZA	HEAD COMP., CYLINDER *NHS*..... DARK GRAY	1	1	1	1	1			
3	12251-zw9-003	GASKET, CYLINDER HEAD	1	1	1	1	1			
4	12310-zw9-000	COVER COMP., HEAD	1	1	1	1	1			
5	12312-zw9-000	PACKING, HEAD COVER	1	1	1	1	1			
6	15611-921-000	CAP, OIL (NO GAUGE)	1	1	1	1	1			
7	16617-zw9-000	HOLDER, CABLE	1	1	1	1	1	SC,S6		
	16617-zw9-010		1	1	1	1	1	1001800 LHC,LHD		

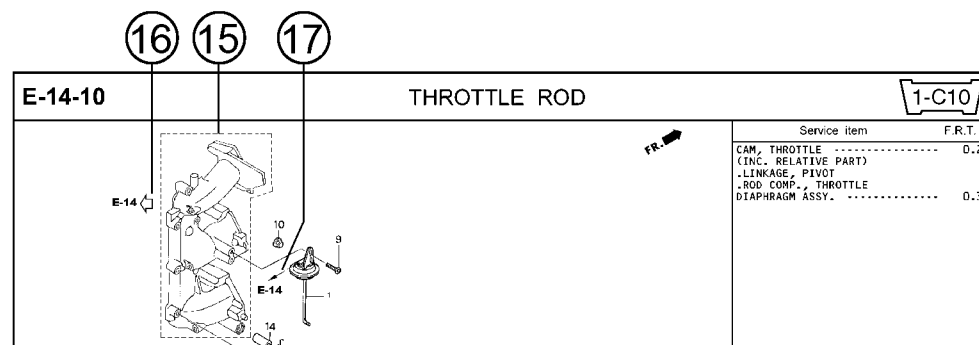

① Address number

- Address No. is provided (in place of the page No.) to help you refer to the part with the part No. or part name.

② Block title ③ Block number

④ Service item/Flat rate time

⑤ Reference number

- Title number marked with the parenthesis or parentheses indicates that it continues from the previous page.

⑥ Part number ⑦ Honda color code

⑧ Description

⑨ Assemblies

- Sections framed with broken lines in the exploded view drawings are available as complete assemblies. (Their individual parts can also be obtained.)

⑩ Color description

⑪ Note

- Notes are shown with the parentheses in the part name column.

⑫ Required quantity

- Required QTY shown in the parenthesis or parentheses indicates the optional part.
- Required QTY marked with "N" Indicates the optional part that should be selected as needed.
- Required QTY indicates the number of the part used in the block.

⑬ Serial number

⑭ Type

- When the type column is blank, it indicates that the part is applicable to all types.
- As the type of the actual unit may differ from the "parts catalogue, type" please refer to "Models, types and applicable serial numbers" for confirmation.

⑮

- Parts enclosed within a dotted line are covered in a different block.

⑯

- A hollow arrow indicates the block No. for the parts enclosed within a dotted line .

⑰

- A solid arrow indicates the block No. the part in question is connected to.

When the parts were revised

Abbreviations used in the parts catalogue

1



Be sure to check the serial number!!



Ref. No.	Part No.	Description	Reqd. QTY						Serial No.
			BF 99D1	BFP 9.9D1	BF 10D1	BFP 10D1	BF 10B1	BFP 10B1	
1	12166-ZW9-000	STOPPER, ENGINE SIDE	2	2	2	2	2	2	
2	12210-ZW9-000ZA	HEAD COMP., CYLINDER *NH8*	1	1	1	1	1	1	
3	12251-ZW9-003	GASKET, CYLINDER HEAD	1	1	1	1	1	1	
4	12310-ZW9-000	COVER COMP., HEAD	1	1	1	1	1	1	
5	12312-ZW9-000	PACKING, HEAD COVER	1	1	1	1	1	1	
6	15611-921-000	CAP, OIL (NO GAUGE)	1	1	1	1	1	1	
7	16617-ZW9-000	HOLDER, CABLE (###)	1	1	1	1	1	1	
	16617-ZW9-010	1	1	1	1	1	1	

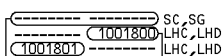

The number has been used from the initial model without revision. When shown at the left side, it is applicable to the models of No.1001801 and the subsequent numbers. When shown at the right side, it is applicable to the models up to No.1001800.

The parts listed with "###" at the end of the parts name have limited supply period (parts not for sale).

The following abbreviations are used in the parts name column.

- A Ampere
- A.C. Alternating current
- ASSY. Assembly
- AT. Automatic transmission
- C.D.I. Capacitive discharge ignition
- COMP. ... Complete
- D.C. Direct current
- EX. Exhaust
- G.F.C.I ... Ground fault circuit interruptor
- HEX. Hexagonal
- H.S.T. Hydrostatic transmission
- FR.Front
- IN.Inlet
- L (100L) .Link (100 Links)
- L.Left
- MMMillimeter
- MT.Manual Transmission
- P.T.O.Power take off
- R.Right
- RR.Rear
- STD.Standard
- T (22T) ...Tooth (22 Teeth)
- V Volt
- WWatt

How to check the part block and serial numbers

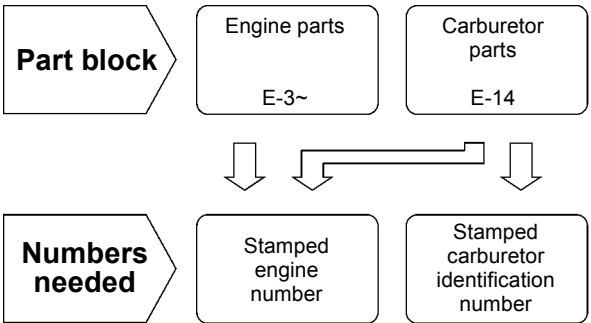

Check point

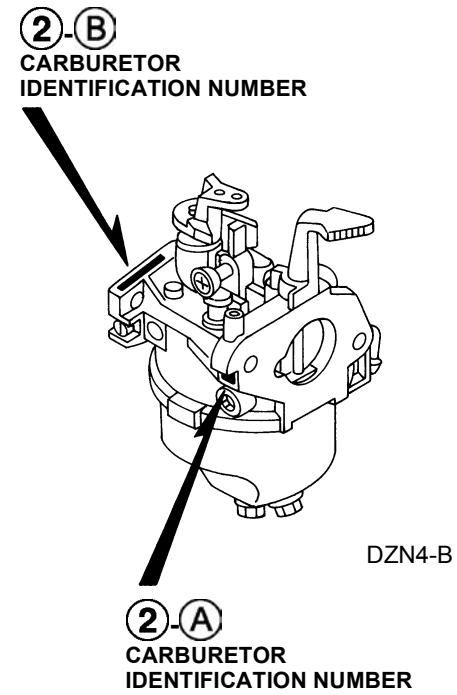
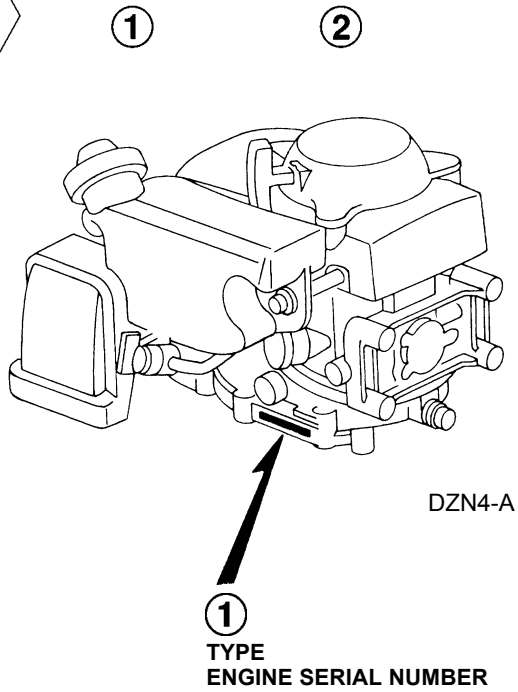

Models, parts catalogue codes and applicable serial numbers

- Models, parts catalogue codes and applicable serial Nos. given in this parts catalogue can be identified as follows.

Model	Type	Parts catalogue type	Applicable engine serial No.	Applicable carburetor identification No.
GXV50	SA	SA	GJAG-1000001~1099999	BF31D A/B
		SA/A	GJAG-1100001~1199999	BF31D B
		SA/B	GJAG-1200001~	
	SAR	SAR	GJAG-1000001~1099999	
		SAR/A	GJAG-1100001~1199999	
		SAR/B	GJAG-1200001~	
	SER	SER	GJAG-1000001~1099999	
		SER/A	GJAG-1100001~1199999	
		SER/B	GJAG-1200001~	
	SJ	SJ	GJAG-1000001~1099999	
		SJ/A	GJAG-1100001~1199999	BF31D B
		SJ/B	GJAG-1200001~	
	VA	VA	GJAG-1000001~1099999	BF31D A/B
		VA/A	GJAG-1100001~1199999	BF31D B
		VA/B	GJAG-1200001~	
VC	VC	GJAG-1000001~1099999	BF31D A/B	
	VC/A	GJAG-1100001~9999999	BF31D B	
VD	VD	GJAG-1000001~1099999	BF31A A,BF31D A/B	
	VD/A	GJAG-1100001~9999999	BF31D B	

Model	Type	Parts catalogue type	Applicable engine serial No.	Applicable carburetor identification No.
GXV50	VE	VE	GJAG-1000001~1099999	BF31A A,BF31D A/B
		VE/A	GJAG-1100001~1199999	BF31D B
		VE/B	GJAG-1200001~	
	VJ	VJ	GJAG-1000001~1099999	BF31A A,BF31D A/B
		VJ/A	GJAG-1100001~1199999	BF31D B
		VJ/B	GJAG-1200001~	
	VJM	VJM	GJAG-1000001~1099999	BF31D B
		VJM/A	GJAG-1100001~1199999	
		VJM/B	GJAG-1200001~	
	VU	VU	GJAG-1000001~1099999	BF31A A,BF31D A/B
		VU/A	GJAG-1100001~9999999	BF31D B
	VYM	VYM	GJAG-1100001~1199999	BF31C B
VYM/A		GJAG-1200001~		

* Of carburetor identification numbers, only the portions underlined in the example below are used for registration.

BF 31D A KC ナ
 (A) (B)

Features of each type

- See the following table for the features of each type.

Specifications		Model	GXV50										
		Type	SA	SAR	SER	SJ	VA	VC	VD	VE	VJ	VJM	VU
Crankshaft	Straight	●	●	●	●								
	Tapered					●	●	●	●	●	●	●	●
Spark arrester		(●)	●	●	(●)	(●)	(●)	(●)	(●)	(●)	(●)	(●)	(●)
Clutch											●		●

Fuel hose, general purpose hoses and vinyl hose

- The standard part fuel hose, general purpose hose and vinyl hose may be substituted by the coiled bulk part.
- When ordering the standard part fuel hose, general purpose hose and vinyl hose use the bulk part number written in the parts catalog in brackets () underneath the part name.
- When exchanging the hose, cut and use at the specified length as mentioned in the part name.
(For the method of cutting the bulk part, and method of filling out orders etc., please refer to the instructions issued with the bulk part.)

Bulk part number of fuel hose, general purpose hose and vinyl hose.

Example: 9 5 0 0 1 - 7 5 0 0 1 - 5 0 M

Bulk part number:
Refers to the bulk part.

Marking code (fuel hose and general purpose hose)

Change code (Vinyl hose)

Indicates number mark or change sequence, however, the code for the bulk part must be strictly 0 (zero).

Types of code:

- | | | | | | |
|-------------|--|----------------|--|--------------|---|
| • Fuel hose | 2: Red outside braid
(3 mm inside dia. only) | • General hose | 1: Ash gray
2: Ash gray
3: Black
5: Black | • Vinyl hose | 1: Clear
2: Black
3: Light red
6: Light red
7: Pale black |
| | 5: Black inside braid | | | | |
| | 3: Red (3 mm inside dia. only) | | | | |
| | 4: Ash gray with red stripe
(3 mm inside dia. only) | | | | |
| | 6: Black | | | | |

Lengths:

- 001: 1 m (standard)
003: 3 m
008: 8 m } Application or specification of some parts is not settled.

I.D code: (fuel hose and general purpose hose)

- | | | | | |
|------------|--------------------|--------------------|-----------------------------|-----------------------------|
| 30: 3.0 mm | 50: 5.0 mm | 70: 7.0 mm | 11: 11 mm | 12: 12 (outside dia. 17) mm |
| 35: 3.5 mm | 55: 5.3 mm, 5.5 mm | 75: 7.3 mm, 7.5 mm | 91: 12 (outside dia. 15) mm | 14: 14 mm |
| 45: 4.5 mm | 65: 6.5 mm | 80: 8.0 mm | 92: 12 (outside dia. 16) mm | 17: 17 mm |

ID./OD. code: (vinyl hose)

- | | | | | |
|-------------------------|--------------------------|---------------------------|---------------------------|---------------------------|
| 01: ID. 2.9, OD. 6.8 mm | 12: ID. 5.0, OD. 7.0 mm | 21: ID. 8.0, OD. 9.0 mm | 37: ID. 11.0, OD. 15.0 mm | 50: ID. 16.0, OD. 19.0 mm |
| 03: ID. 3.0, OD. 6.0 mm | 10: ID. 5.0, OD. 8.0 mm | 23: ID. 8.0, OD. 12.0 mm | 38: ID. 12.0, OD. 13.0 mm | 55: ID. 17.5, OD. 20.5 mm |
| 05: ID. 3.5, OD. 6.5 mm | 11: ID. 5.0, OD. 9.0 mm | 25: ID. 9.0, OD. 11.0 mm | 39: ID. 12.0, OD. 14.0 mm | 60: ID. 22.0, OD. 27.0 mm |
| 07: ID. 4.0, OD. 7.0 mm | 14: ID. 6.0, OD. 9.0 mm | 27: ID. 9.0, OD. 13.0 mm | 40: ID. 12.0, OD. 16.0 mm | |
| 08: ID. 4.5, OD. 6.5 mm | 17: ID. 7.0, OD. 9.0 mm | 33: ID. 10.0, OD. 14.0 mm | 43: ID. 13.0, OD. 15.0 mm | |
| 09: ID. 4.5, OD. 8.0 mm | 19: ID. 7.0, OD. 11.0 mm | 36: ID. 11.0, OD. 13.0 mm | 45: ID. 14.0, OD. 18.0 mm | |

Hose type:

- 1: Fuel hose
3: Vinyl hose
5: General hose

⊙ **CAUTION: It is DANGEROUS to confuse the fuel hose with the general purpose hose or vinyl hose.**

Never use a general purpose hose or vinyl hose in place of a fuel hose or vice versa. Always use the correct bulk part in the parts catalogue, according to the service manual or the instructions issued with the bulk part.

ENGINE GROUP

B10

E-3

CYLINDER BARREL

C 1

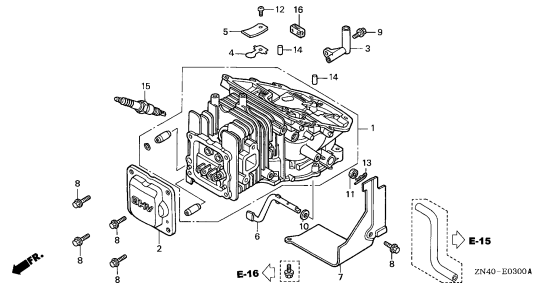

E-5

OIL CASE

C 3

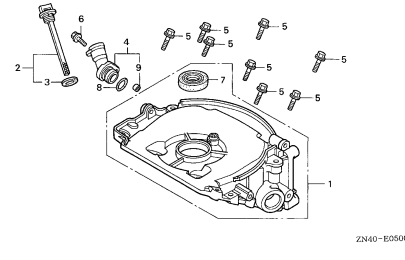

E-6

CRANKCASE SIDE COVER

C 4

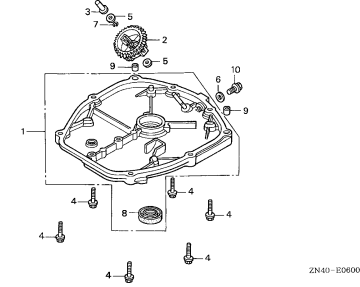

E-7

CRANKSHAFT

C 5

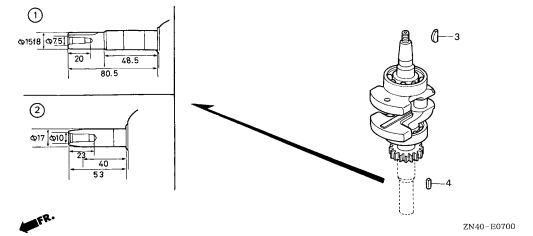

E-8

PISTON/CONNECTING ROD

C 6

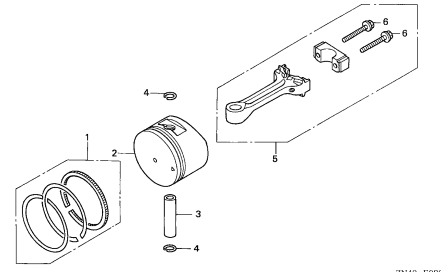

E-9

CAMSHAFT

C 7

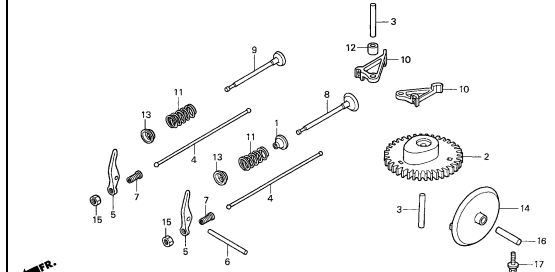

E-11

RECOIL STARTER

C 9

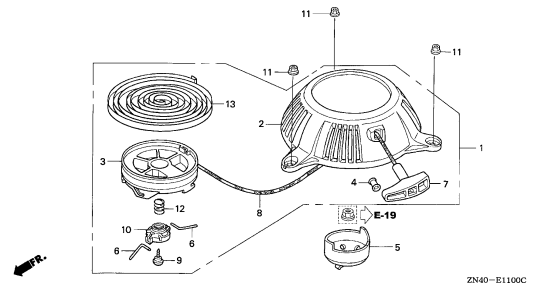

E-12

FAN COVER

C10

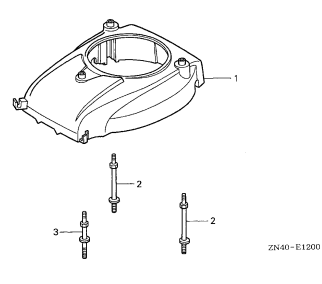

E-14

CARBURETOR

C11

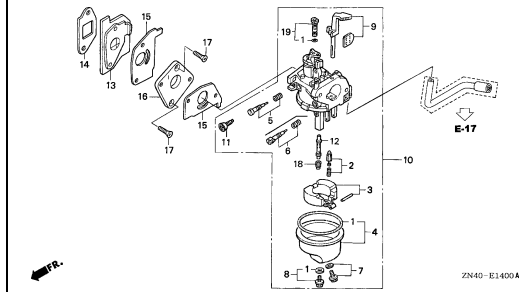

2

ENGINE GROUP

B11

E-15

AIR CLEANER

C13

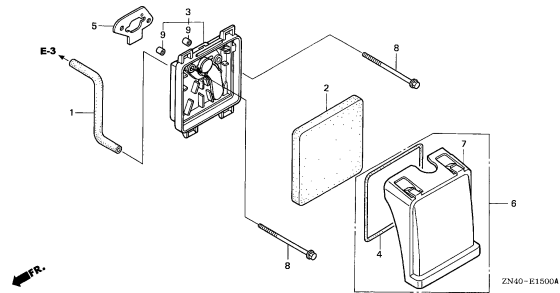

E-16

MUFFLER

C14

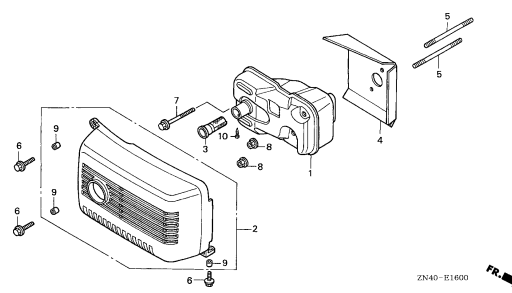

E-17

FUEL TANK

C15

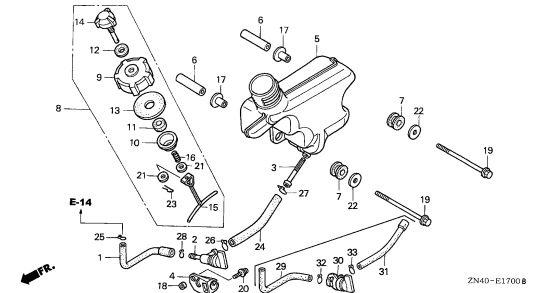

E-19

FLYWHEEL/IGNITION COIL

D 1

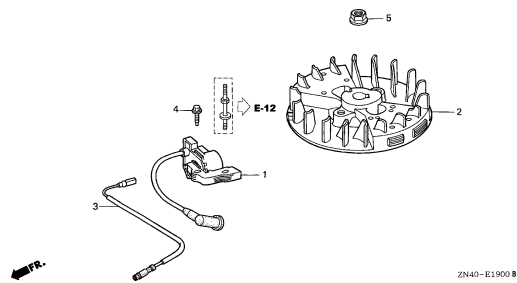

E-22

CONTROL

D 2

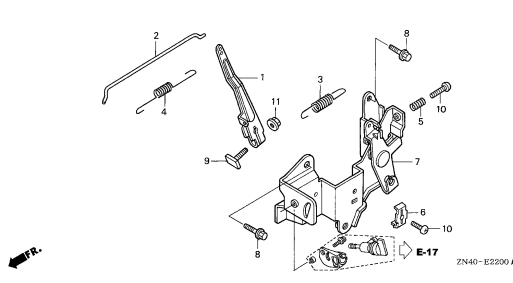

E-26

CLUTCH

D 3

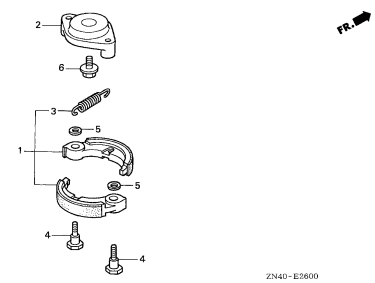

E-28

LABEL

D 4

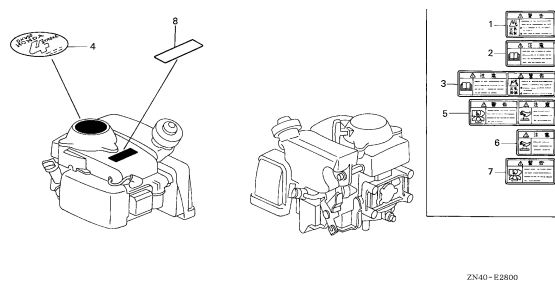

E-29

TOOL

D 5

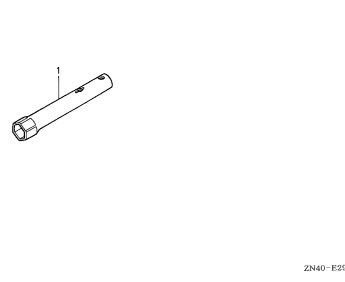

2

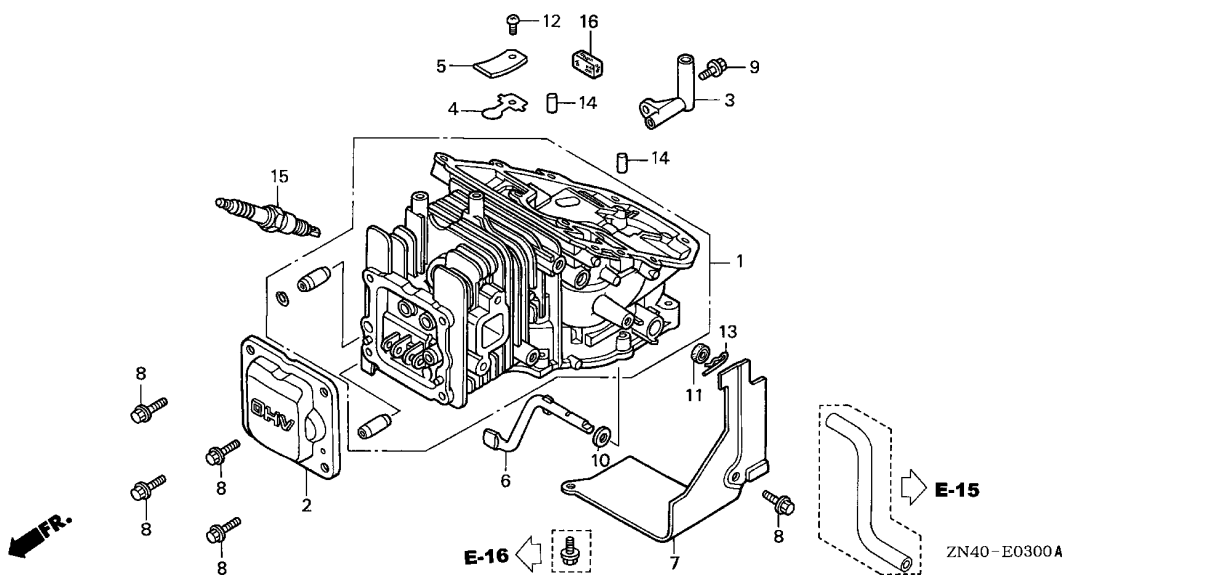

Service item	F.R.T.

Ref. No.	Part No.	Description	Reqd. QTY		Serial No.	Parts catalogue code
			GXV	50		
1	12100-ZM7-000 12100-ZM7-407 12100-ZM7-417	BARREL COMP., CYLINDER	1	1	----- 1115501 -----	SA,SAR,SER,SJ,VA,VC,VC/A,VD,VD/A,VE,VJ,VJM,VU,VU/A SA/A,SAR/A,SER/A,SJ/A,VA/A,VE/A,VJ/A,VJM/A,VYM SA/B,SAR/B,SER/B,SJ/B,VA/B,VE/B,VJ/B,VJM/B,VYM/A
2	12311-ZM7-000 12311-ZM7-010	COVER, HEAD	1	1	----- -----	SA/A,SAR/A,SER/A,SJ/A,VA/A,VE/A,VJ/A,VJM/A,VYM SA,SAR,SER,SJ,VA,VC,VC/A,VD,VD/A,VE,VJ,VJM,VU,VU/A SA/A,SA/B,SAR/A,SAR/B,SER/A,SER/B,SJ/A,SJ/B,VA/A,VA/B,VE/A,VE/B,VJ/A,VJ/B VJM/A,VJM/B,VYM,VYM/A
3	15171-ZN4-000	PIPE, BREATHER	1	1	-----	-----
4	15571-ZM7-003	VALVE, OIL OUTLET	1	1	-----	-----
5	15572-ZM7-000	PLATE, STOPPER	1	1	-----	-----
6	16541-ZM7-000	SHAFT, GOVERNOR ARM	1	1	-----	-----
7	19631-ZM7-000	SHROUD	1	1	-----	-----
8	90003-892-000	BOLT, FLANGE, 5X12	5	5	-----	-----
9	90008-ZM7-000	BOLT, 4X10	1	1	-----	-----
10	90443-ZC3-000	WASHER, 5.2X9	1	1	-----	-----
11	91231-ZC3-003	OIL SEAL, 5X11X5	1	1	-----	-----
12	93500-03005-0A	SCREW, PAN, 3X5	1	1	-----	-----
13	94251-06000	PIN, LOCK, 6MM	1	1	-----	-----
14	96220-60150	ROLLER, 6X15	2	2	-----	-----
15	98056-54750 98056-54757	PLUG, SPARK (U14FS-UB) (DENSO)	(1)	(1)	----- -----	SJ,SJ/A,SJ/B,VD,VD/A,VJ,VJ/A,VJ/B,VJM,VJM/A,VJM/B,VYM,VYM/A SA,SA/A,SA/B,SAR,SAR/A,SAR/B,SER,SER/A,SER/B,VA,VA/A,VA/B,VC,VC/A,VE,VE/A VE/B,VU,VU/A
	98056-54770 98056-54777	PLUG, SPARK (C4HSB) (NGK)	(1)	(1)	----- -----	SJ,SJ/A,SJ/B,VD,VD/A,VJ,VJ/A,VJ/B,VJM,VJM/A,VJM/B,VYM,VYM/A SA,SA/A,SA/B,SAR,SAR/A,SAR/B,SER,SER/A,SER/B,VA,VA/A,VA/B,VC,VC/A,VE,VE/A VE/B,VU,VU/A
	98056-55750	PLUG, SPARK (U16FS-UB)	1	1	-----	SJ,SJ/A,SJ/B,VD,VD/A,VJ,VJ/A,VJ/B,VJM,VJM/A,VJM/B,VYM,VYM/A

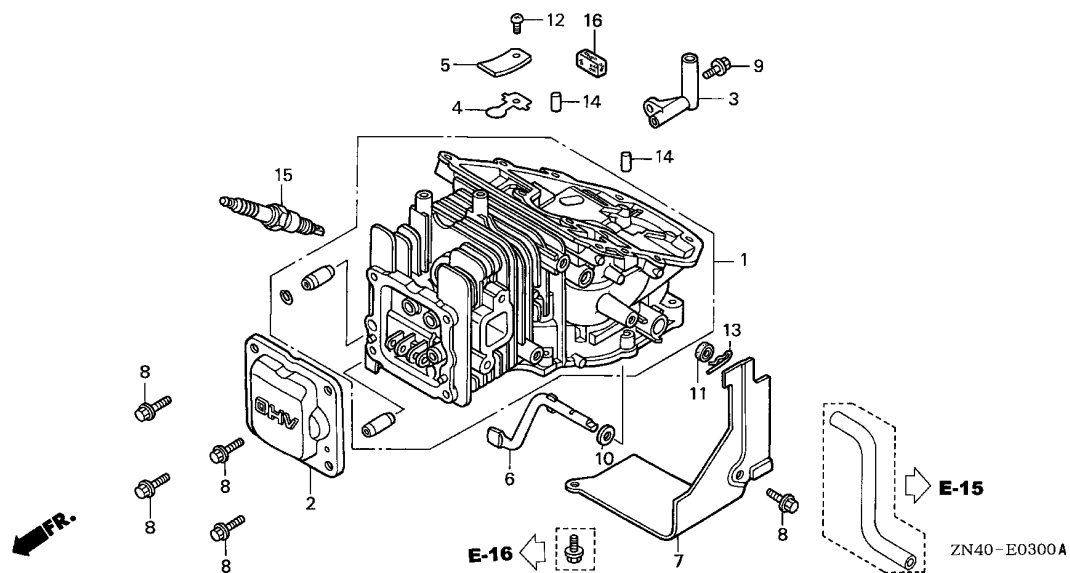

Ref. No.	Part No.	Description	Reqd. QTY		Serial No.	Parts catalogue code
				GXV 50		
15)	98056-55757	PLUG, SPARK (U16FSR-UB)	1	-----	SA,SA/A,SA/B,SAR,SAR/A,SAR/B,SER,SER/A,SER/B,VA,VA/A,VA/B,VC,VC/A,VE,VE/A,VE/B,VU,VU/A	
	98056-55770	PLUG, SPARK (C5HSB)	1	-----	SJ,SJ/A,SJ/B,VD,VD/A,VJ,VJ/A,VJ/B,VJM,VJM/A,VJM/B,VYM,VYM/A	
	98056-55777	PLUG, SPARK (CR5HSB)	1	-----	SA,SA/A,SA/B,SAR,SAR/A,SAR/B,SER,SER/A,SER/B,VA,VA/A,VA/B,VC,VC/A,VE,VE/A,VE/B,VU,VU/A	
16	12367-ZE6-010	FILTER, BREATHER	1	-----	VJM,VJM/A,VJM/B,VYM,VYM/A	

E-5

OIL CASE

C 3

Service item

F.R.T.

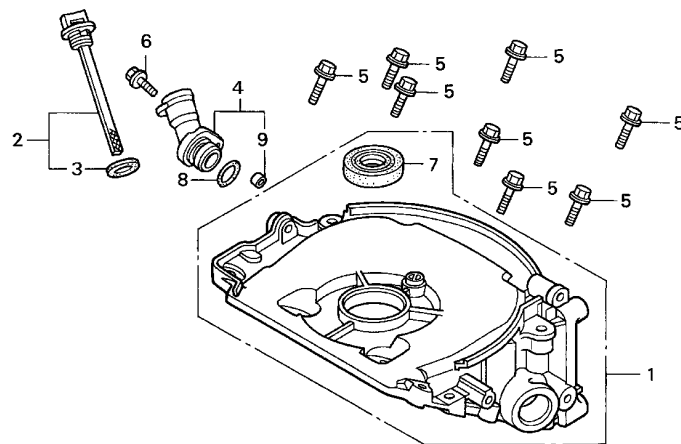

ZN40-E0500

FR.

Ref. No.	Part No.	Description	Reqd. QTY		Serial No.	Parts catalogue code
			GXV	50		
1	11300-ZN4-405	CASE ASSY., OIL	1			
2	15600-ZN4-003	CAP ASSY., OIL FILLER	1			
3	15625-ZE1-003	PACKING, OIL FILLER CAP	1			
4	15631-ZN4-000	EXTENSION, OIL FILLER	1			
5	90006-ZM7-000	BOLT, FLANGE, 5X23	8			
6	90012-896-750	BOLT, FLANGE, 5X14	1			
7	91202-HC5-003	OIL SEAL, 17X27X5 (ARAI)	1			
8	91331-PC9-003	O-RING, 21.2X2.4 (ARAI)	1			
9	91502-ZM3-000	COLLAR, TOP COVER	1			

2

E-6

CRANKCASE SIDE COVER

C 4

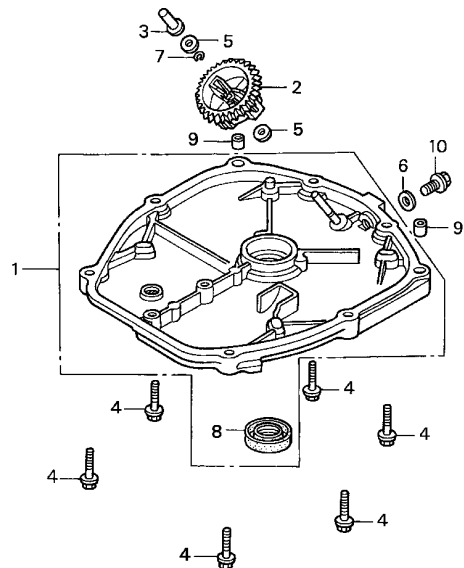

ZN40-E0600

Service item F.R.T.

Ref. No.	Part No.	Description	Reqd. QTY		Serial No.	Parts catalogue code
				GXV 50		
1	11340-ZN4-010	COVER COMP., CRANKCASE SIDE	1	1030744	SA,SAR,SER,SJ,VD,VE,VJ,VJM	
	11340-ZN4-020	1	-----	SA/A,SA/B,SAR/A,SAR/B,SER/A,SER/B,SJ/A,SJ/B,VD/A,VE/A,VE/B,VJ/A,VJ/B	
	11340-ZN4-801	1	1030745	VJM/A,VJM/B,VYM,VYM/A	
	11340-ZN4-802	1	-----	SA,SAR,SER,SJ,VD,VE,VJ,VJM	
		1	1030744	VA,VC,VU	
		1	-----	VA/A,VA/B,VC/A,VU/A	
		1	1030745	VA,VC,VU	
2	16510-ZM7-000	GOVERNOR ASSY.	1			
3	16531-ZM7-000	SLIDER, GOVERNOR	1			
4	90006-ZM7-000	BOLT, FLANGE, 5X23	6			
5	90441-ZM7-000	WASHER, 4.2X13	2			
6	90471-580-000	PACKING, 8MM	1			
7	90602-ZM7-000	CLIP, GOVERNOR HOLDER	1			
8	91202-HC5-003	OIL SEAL, 17X27X5 (ARAI)	1			
9	94301-06100	DOWEL PIN, 6X10	2			
10	95701-08012-08	BOLT, FLANGE, 8X12	1			

2

Service item F.R.T.

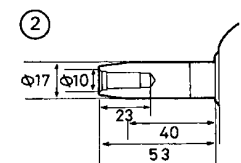
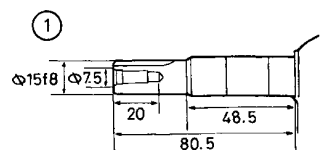

FR.

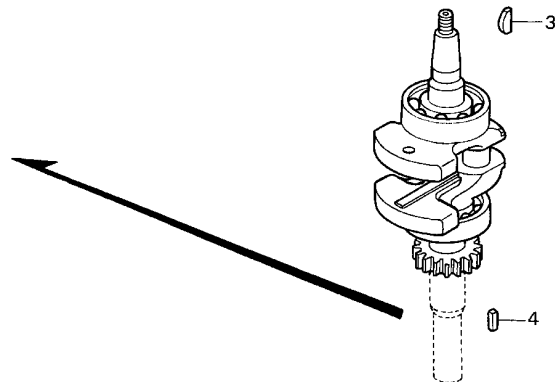

ZN40-E0700

Ref. No.	Part No.	Description	Reqd. QTY		Serial No.	Parts catalogue code
			GXV	50		
1	13310-ZM7-000	CRANKSHAFT COMP.	1	-----	-----	SA,SA/A,SA/B,SAR,SAR/A,SAR/B,SER,SER/A,SER/B,SJ,SJ/A,SJ/B
2	13310-ZN4-000	CRANKSHAFT COMP.	1	-----	-----	VA,VA/A,VA/B,VC,VC/A,VD,VD/A,VE,VE/A,VE/B,VJ,VJ/A,VJ/B,VJM,VJM/A,VJM/B,VU VU/A,VYM,VYM/A
3	13331-ZM7-000	KEY, SPECIAL	1	-----	-----	
4	90741-959-000	KEY, 5MM	(1)	-----	-----	SA,SA/A,SA/B,SAR,SAR/A,SAR/B,SER,SER/A,SER/B,SJ,SJ/A,SJ/B

E-8

PISTON/CONNECTING ROD

C 6

Service item

F.R.T.

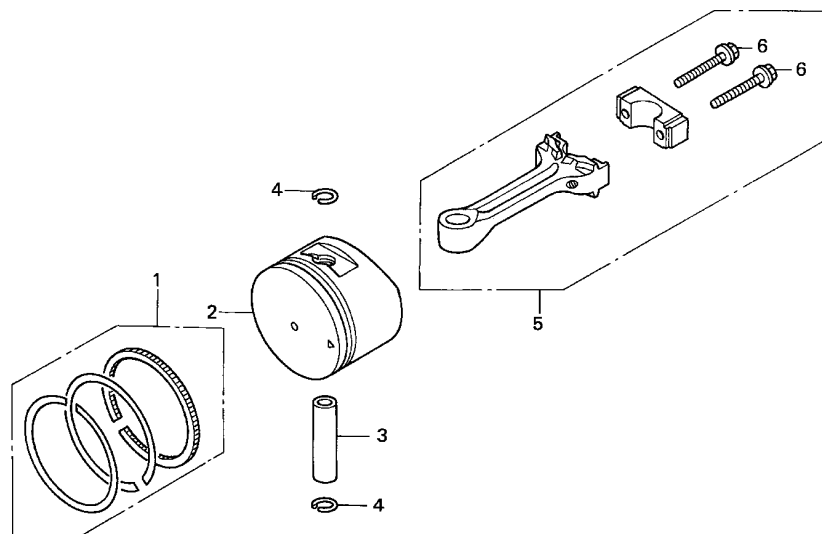

ZN40-E0800

Ref. No.	Part No.	Description	Reqd. QTY		Serial No.	Parts catalogue code
			GXV	50		
1	13010-ZM7-000	RING SET, PISTON (STD.)	1			
2	13101-ZM7-000	PISTON (STD.)	1		----- 1032236	SA,SAR,SER,SJ,VA,VC,VD,VE,VJ,VJM,VU
	13101-ZM7-010	1		-----	SA/A,SA/B,SAR/A,SAR/B,SER/A,SER/B,SJ/A,SJ/B,VA/A,VA/B,VC/A,VD/A,VE/A,VE/B VJ/A,VJ/B,VJM/A,VJM/B,VU/A,VYM,VYM/A
3	13111-122-000	PIN, PISTON, 10X33	1		1032237	----- SA,SAR,SER,SJ,VA,VC,VD,VE,VJ,VJM,VU
4	13115-147-000	CLIP, PISTON PIN, 10MM	2			
5	13200-ZN4-000	ROD ASSY., CONNECTING	1			
6	90001-ZM7-000	BOLT, CONNECTING ROD	2			

2

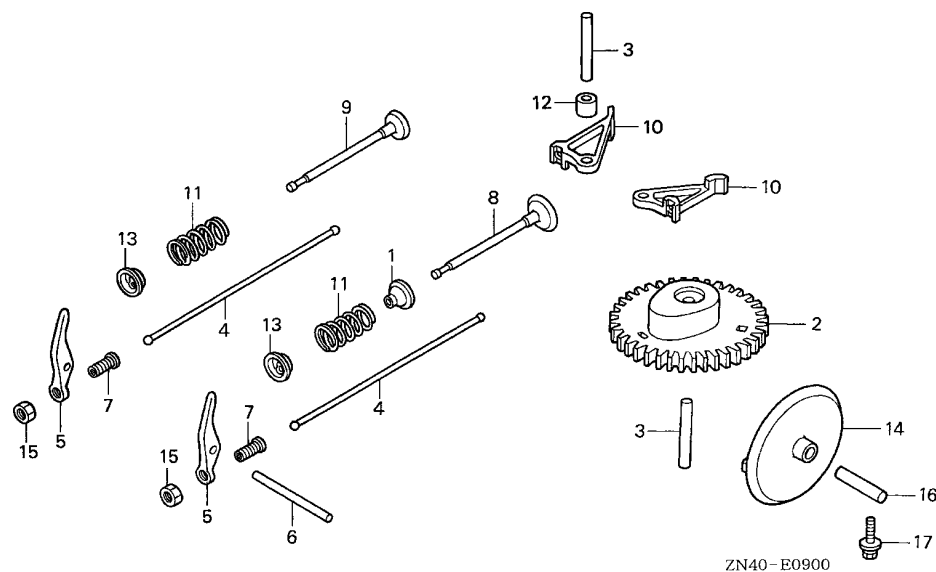

Service item

F.R.T.

Ref. No.	Part No.	Description	Reqd. QTY		Serial No.	Parts catalogue code
			GXV	50		
1	12209-ZM7-003	SEAL, VALVE STEM	1			
2	14100-ZM7-000	CAMSHAFT ASSY.	1		1005258	SA,SJ,VA,VC,VD,VE,VJ,VU
	14100-ZM7-010	1			SA/A,SA/B,SAR,SAR/A,SAR/B,SER,SER/A,SER/B,SJ/A,SJ/B,VA/A,VA/B,VC/A,VD/A,VE/A,VE/B,VJ/A,VJ/B,VJM,VJM/A,VJM/B,VU/A,VYM,VYM/A
3	90702-P6R-008	PIN, OIL PUMP	1		1005259	SA,SJ,VA,VC,VD,VE,VJ,VU
	14126-Z0G-003	ROLLER (5X29.8)	2		1030744	SA,SAR,SER,SJ,VA,VC,VD,VE,VJ,VJM,VU
		2			SA/A,SA/B,SAR/A,SAR/B,SER/A,SER/B,SJ/A,SJ/B,VA/A,VA/B,VC/A,VD/A,VE/A,VE/B,VJ/A,VJ/B,VJM/A,VJM/B,VU/A,VYM,VYM/A
4	14410-ZM7-000	ROD, PUSH	2		1030745	SA,SAR,SER,SJ,VA,VC,VD,VE,VJ,VJM,VU
5	14431-ZM7-000	ARM, VALVE ROCKER	2			
6	14435-ZM7-003	ROLLER (4X37.8)	1			
7	14451-ZM7-000	PIVOT, ROCKER ARM	2			
8	14711-ZM7-000	VALVE, IN.	1			
9	14721-ZM7-000	VALVE, EX.	1			
10	14731-ZM7-003	LIFTER, VALVE	2		1006420	SA,SJ,VA,VC,VD,VE,VJ,VU
	14731-ZM7-013	2			SA/A,SA/B,SAR,SAR/A,SAR/B,SER,SER/A,SER/B,SJ/A,SJ/B,VA/A,VA/B,VC/A,VD/A,VE/A,VE/B,VJ/A,VJ/B,VJM,VJM/A,VJM/B,VU/A,VYM,VYM/A
		2		1006421	SA,SJ,VA,VC,VD,VE,VJ,VU
11	14751-ZM7-000	SPRING, VALVE	2			
12	14754-ZM7-000	COLLAR, LIFTER	1			
13	14771-ZM3-000	RETAINER, VALVE SPRING	2		1003434	SA,SJ,VA,VC,VD,VE,VJ,VU
	14771-ZM3-010	2			SA/A,SA/B,SAR,SAR/A,SAR/B,SER,SER/A,SER/B,SJ/A,SJ/B,VA/A,VA/B,VC/A,VD/A,VE/A,VE/B,VJ/A,VJ/B,VJM,VJM/A,VJM/B,VU/A,VYM,VYM/A
		2		1003435	SA,SJ,VA,VC,VD,VE,VJ,VU
14	15361-ZN4-000	SLINGER, OIL	1			
15	90206-KM3-000	NUT, TAPPET ADJUSTING	2			

E-9

CAMSHAFT

C 8

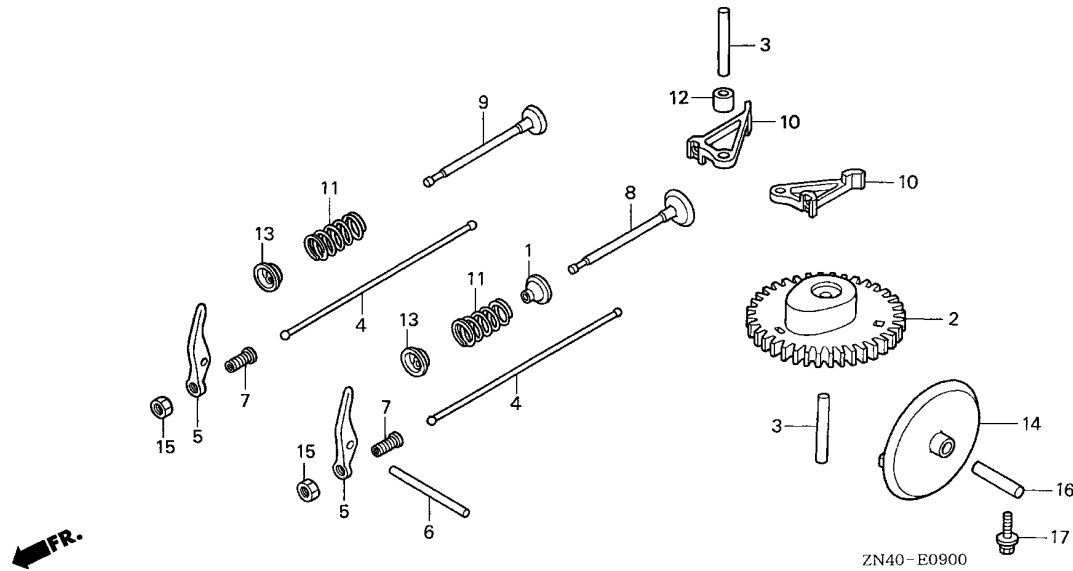

FR. ←

Ref. No.	Part No.	Description	Reqd. QTY		Serial No.	Parts catalogue code
			GXV	50		
16	91151-VB5-800	ROLLER, 6X25	1			
17	93404-05016-08	BOLT-WASHER, 5X16	1			

2

Service item F.R.T.

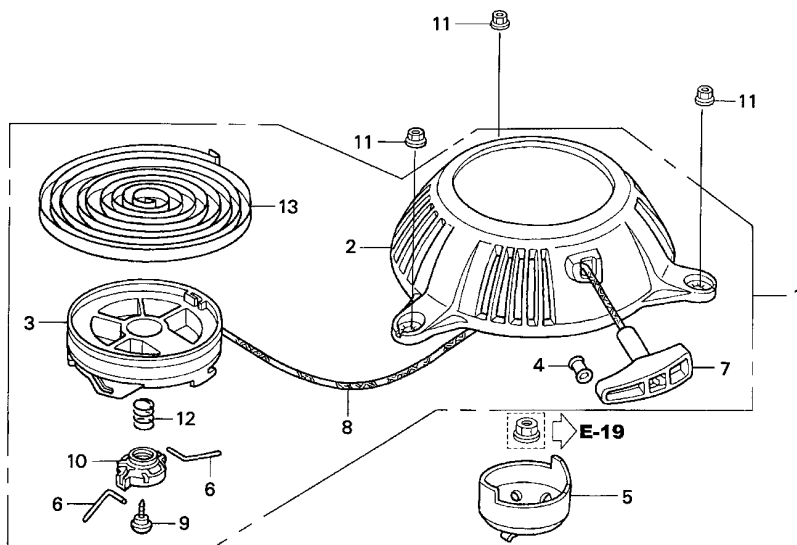

ZN40-E1100C



2

Ref. No.	Part No.	Description	Reqd. QTY		Serial No.	Parts catalogue code
				GXV 50		
1	28400-ZM7-003	STARTER ASSY., RECOIL	1			
2	28414-ZM7-003	CASE, RECOIL STARTER	1			
3	28421-ZM7-003	REEL, RECOIL STARTER	1			
4	28433-ZM3-003	GUIDE, ROPE	1			
5	28451-ZM7-003	PULLEY, RECOIL STARTER	1			
6	28459-ZM7-003	ARM, SWING	2			
7	28461-ZM3-003	KNOB, RECOIL STARTER	1			
8	28462-ZM7-003	ROPE, RECOIL STARTER	1			
9	90012-ZM3-003	SCREW, SETTING	1			
10	91504-ZM7-003	COLLAR	1			
11	94050-05000	NUT, FLANGE, 5MM	3			
12	28404-968-004	SPRING, FRICTION	1			
13	28442-ZL8-003	SPRING, RECOIL STARTER	1			

Service item

F.R.T.

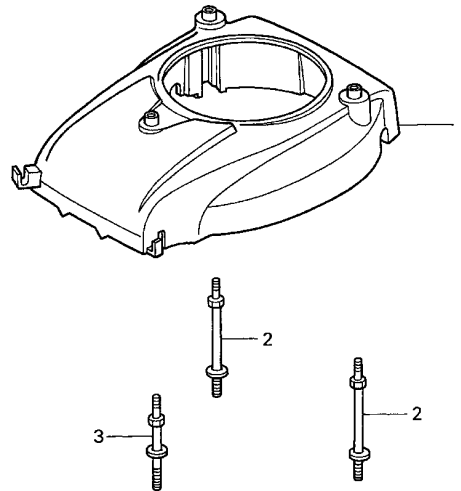

Ref. No.	Part No.	Description	Reqd. QTY		Serial No.	Parts catalogue code
				GXV 50		
1	19610-ZM7-000ZA	COVER COMP., FAN *R8*.....BRIGHT RED	1		----- SA,SAR,SER,SJ,VA,VC,VC/A,VD,VD/A,VE,VJ,VJM,VU,VU/A	
			1		1110563 SA/A,SAR/A,SER/A,SJ/A,VA/A,VE/A,VJ/A,VJM/A	
	19610-ZM7-000ZC	*R280*.....POWER RED	1		----- SA/B,SAR/B,SER/B,SJ/B,VA/B,VE/B,VJ/B,VJM/B,VYM,VYM/A	
			1		1110564 SA/A,SAR/A,SER/A,SJ/A,VA/A,VE/A,VJ/A,VJM/A	
2	90042-ZM7-000	BOLT, STUD (A)	2			
3	90043-ZM7-000	BOLT, STUD (B)	1			



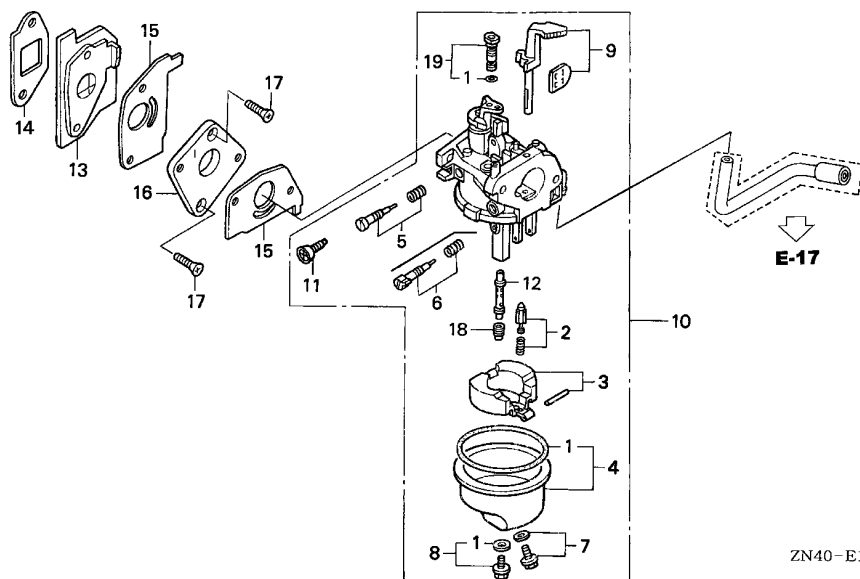

Service item F.R.T.

2

Ref. No.	Part No.	Description	Reqd. QTY		Serial No.	Parts catalogue code
			GXV	50		
1	16010-ZG0-015	GASKET SET	1	-----	-----	SA,SA/A,SA/B,SAR,SAR/A,SAR/B,SER,SER/A,SER/B,SJ,SJ/A,SJ/B,VA,VA/A,VA/B,VC/A,VD,VD/A,VE,VE/A,VE/B,VJ,VJ/A,VJ/B,VJM,VJM/A,VJM/B,VU,VU/A
	16010-ZN4-A01	1	-----	-----	VYM,VYM/A
2	16011-ZE0-005	VALVE SET, FLOAT	1	-----	-----	
3	16013-ZG0-811	FLOAT SET	1	-----	-----	
4	16015-ZG0-811	CHAMBER SET, FLOAT	1	-----	-----	SA,SA/A,SA/B,SAR,SAR/A,SAR/B,SER,SER/A,SER/B,SJ,SJ/A,SJ/B,VA,VA/A,VA/B,VC/A,VD,VD/A,VE,VE/A,VE/B,VJ,VJ/A,VJ/B,VJM,VJM/A,VJM/B,VU,VU/A
	16015-ZG1-D20	1	-----	-----	VYM,VYM/A
5	16016-ZE0-005	SCREW SET, PILOT (CARBURETOR NO.)	1	-----	BF31A A	SJ,VD,VE,VJ,VU
6	16016-ZH7-W01	SCREW SET, PILOT (CARBURETOR NO.)	1	-----	-----	SA,SA/A,SA/B,SAR,SAR/A,SAR/B,SER,SER/A,SER/B,SJ/A,SJ/B,VA,VA/A,VA/B,VC/A,VD/A,VE/A,VE/B,VJ/A,VJ/B,VJM,VJM/A,VJM/B,VU/A,VYM,VYM/A
7	16024-ZE1-811	SCREW SET, DRAIN	1	-----	BF31D A	SJ,VD,VE,VJ,VU
	16024-ZH7-A20	1	-----	-----	SA,SA/A,SA/B,SAR,SAR/A,SAR/B,SER,SER/A,SER/B,SJ,SJ/A,SJ/B,VA,VA/A,VA/B,VC/A,VD,VD/A,VE,VE/A,VE/B,VJ,VJ/A,VJ/B,VJM,VJM/A,VJM/B,VU,VU/A
8	16028-ZG0-811	SCREW SET	1	-----	-----	VYM,VYM/A
9	16044-ZM7-003	CHOKE SET	1	-----	-----	
10	16100-ZN4-003	CARBURETOR ASSY. (BF31A A) ..	1	-----	1007276	SJ,VD,VE,VJ,VU
	16100-ZN4-801	CARBURETOR ASSY. (BF31D A) ..	1	-----	1011658	SA,VA,VC
	16100-ZN4-803	CARBURETOR ASSY. (BF31D B) ..	1	-----	1007277	1011658 SJ,VD,VE,VJ,VU
			1	-----	-----	SA/A,SA/B,SAR,SAR/A,SAR/B,SER,SER/A,SER/B,SJ/A,SJ/B,VA/A,VA/B,VC/A,VD/A,VE/A,VE/B,VJ/A,VJ/B,VJM,VJM/A,VJM/B,VU/A
	16100-ZN4-A12	CARBURETOR ASSY. (BF31C B) ..	1	-----	1011659	SA,SJ,VA,VC,VD,VE,VJ,VU
			1	-----	-----	VYM,VYM/A
11	16124-ZE0-005	SCREW, THROTTLE STOP	1	-----	-----	

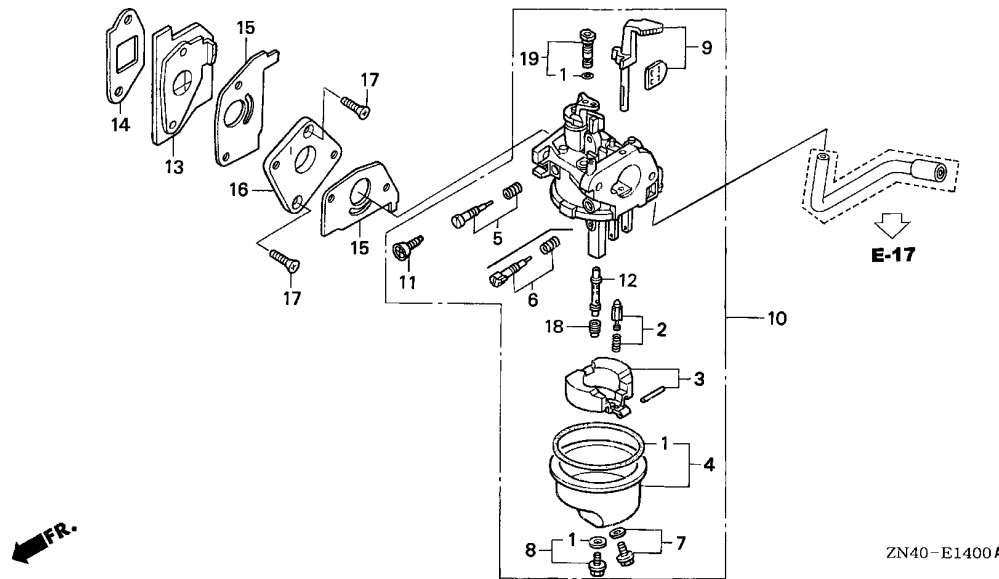

Ref. No.	Part No.	Description	Reqd. QTY		Serial No.	Parts catalogue code
			GXV	50		
12	16166-ZM7-003	NOZZLE, MAIN	1		-----	SA,SA/A,SA/B,SAR,SAR/A,SAR/B,SER,SER/A,SER/B,SJ,SJ/A,SJ/B,VA,VA/A,VA/B,VC/A,VD,VD/A,VE,VE/A,VE/B,VJ,VJ/A,VJ/B,VJM,VJM/A,VJM/B,VU,VU/A
	16166-ZN4-A01		1		-----	VYM,VYM/A
13	16211-ZN4-000	INSULATOR, CARBURETOR	1		-----	
14	16212-ZM7-000	PACKING, INSULATOR	1		-----	
15	16221-ZG0-801	PACKING, CARBURETOR	2		-----	
16	16225-ZN4-000	PLATE, CARBURETOR JOINT	1		-----	
17	93600-05020-0A	SCREW, FLAT, 5X20	2		-----	
18	99101-ZG0-0500	JET, MAIN, #50	(1)		-----	
	99101-ZG0-0520	JET, MAIN, #52	(1)		-----	
	99101-ZG0-0550	JET, MAIN, #55	1		-----	
19	99204-ZE2-0350	JET SET, PILOT, #35	1		-----	SA,SA/A,SA/B,SAR,SAR/A,SAR/B,SER,SER/A,SER/B,SJ,SJ/A,SJ/B,VA,VA/A,VA/B,VC/A,VD,VD/A,VE,VE/A,VE/B,VJ,VJ/A,VJ/B,VJM,VJM/A,VJM/B,VU,VU/A
	99204-ZE2-0380	JET SET, PILOT, #38	1		-----	VYM,VYM/A



E-15

AIR CLEANER

C13

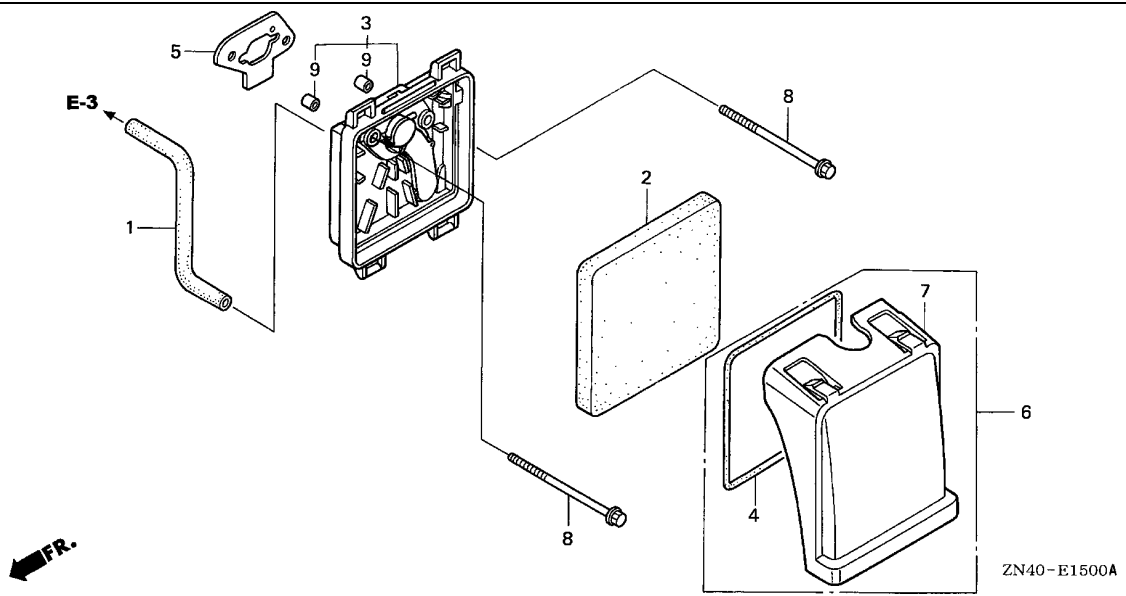

Service item	F.R.T.
--------------	--------

Ref. No.	Part No.	Description	Reqd. QTY		Serial No.	Parts catalogue code
			GXV	50		
1	15721-ZN4-000	TUBE, BREATHER	1			
2	17211-ZM7-000	ELEMENT, AIR CLEANER	1			
3	17220-ZM7-000	CASE COMP., AIR CLEANER	1			
4	17227-ZM7-000	SEAL, AIR CLEANER	1			
5	17228-ZM7-000	PACKING, AIR CLEANER	1			
6	17230-ZM7-000	COVER COMP., AIR CLEANER	1			
7	17231-ZM7-000	COVER, AIR CLEANER	1			
8	90004-ZN4-000	BOLT, FLANGE, 5X65	2			
9	91503-ZM7-000	COLLAR, AIR CLEANER	2			

2

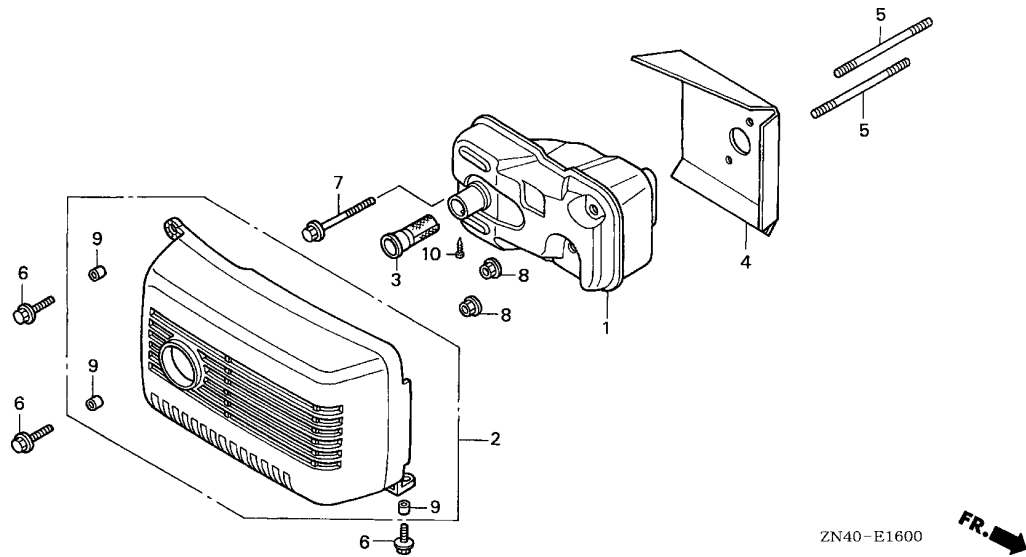

Service item F.R.T.

Ref. No.	Part No.	Description	Reqd. QTY		Serial No.	Parts catalogue code
			GXV	50		
1	18310-ZM7-003	MUFFLER COMP.	1	-----	-----	SA,SA/A,SA/B,SJ,SJ/A,SJ/B,VA,VA/A,VA/B,VC,VC/A,VD,VD/A,VE,VE/A,VE/B,VJ VJ/A,VJ/B,VJM,VJM/A,VJM/B,VU,VU/A,VYM,VYM/A
	18310-ZM7-801	1	-----	-----	SAR,SAR/A,SAR/B,SER,SER/A,SER/B
			(1)	-----	-----	SA,SA/A,SA/B,SJ,SJ/A,SJ/B,VA,VA/A,VA/B,VC,VC/A,VD,VD/A,VE,VE/A,VE/B,VJ VJ/A,VJ/B,VJM,VJM/A,VJM/B,VU,VU/A,VYM,VYM/A
2	18320-ZM7-000	PROTECTOR COMP., MUFFLER	1	-----	-----	SAR,SAR/A,SAR/B,SER,SER/A,SER/B
3	18350-ZM7-801	ARRESTER COMP., SPARK	1	-----	-----	SA,SA/A,SA/B,SJ,SJ/A,SJ/B,VA,VA/A,VA/B,VC,VC/A,VD,VD/A,VE,VE/A,VE/B,VJ VJ/A,VJ/B,VJM,VJM/A,VJM/B,VU,VU/A,VYM,VYM/A
			(1)	-----	-----	SA,SA/A,SA/B,SJ,SJ/A,SJ/B,VA,VA/A,VA/B,VC,VC/A,VD,VD/A,VE,VE/A,VE/B,VJ VJ/A,VJ/B,VJM,VJM/A,VJM/B,VU,VU/A,VYM,VYM/A
4	18515-ZM7-000	GUIDE, AIR	1	-----	-----	
5	90002-ZM7-000	BOLT, STUD, 2,5X55	2	-----	-----	
6	90012-892-000	BOLT, FLANGE, 5X16	3	-----	-----	
7	90103-P4V-010	BOLT, FLANGE, 5X35	1	-----	-----	
8	90136-SM4-901	NUT, SELF-LOCK, 5MM	2	-----	-----	
9	91502-ZM3-000	COLLAR, TOP COVER	3	-----	-----	
10	93903-24110	SCREW, TAPPING, 4X8	1	-----	-----	SAR,SAR/A,SAR/B,SER,SER/A,SER/B
			(1)	-----	-----	SA,SA/A,SA/B,SJ,SJ/A,SJ/B,VA,VA/A,VA/B,VC,VC/A,VD,VD/A,VE,VE/A,VE/B,VJ VJ/A,VJ/B,VJM,VJM/A,VJM/B,VU,VU/A,VYM,VYM/A



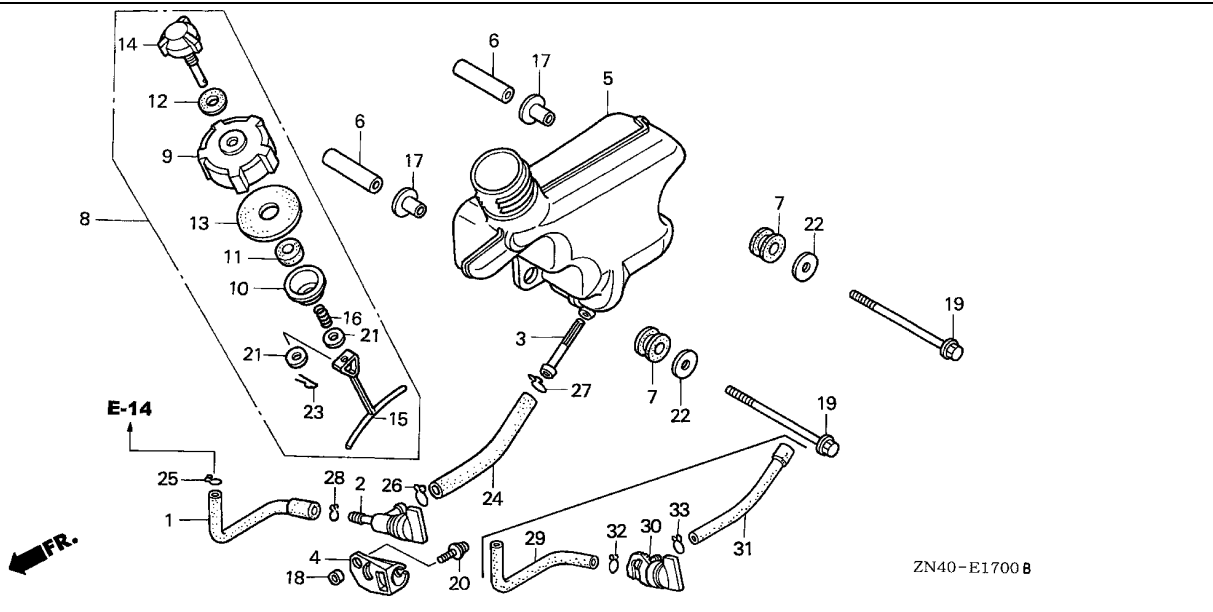

Service item	F.R.T.

Ref. No.	Part No.	Description	Reqd. QTY		Serial No.	Parts catalogue code
			GXV	50		
1	16861-ZN4-000	TUBE B, FUEL	1	-----	-----	SA,SAR,SER,SJ,VA,VC,VC/A,VD,VD/A,VE,VJ,VJM,VU,VU/A
2	16950-ZG9-M02	COCK ASSY., FUEL	1	-----	1116665	SA/A,SAR/A,SER/A,SJ/A,VA/A,VE/A,VJ/A,VJM/A,VYM
	16950-ZG9-M03	1	-----	1116665	SA/A,SAR/A,SER/A,SJ/A,VA/A,VE/A,VJ/A,VJM/A,VYM
3	16952-ZE6-000	STRAINER, FUEL	1	-----	-----	SA,SAR,SER,SJ,VA,VC,VC/A,VD,VD/A,VE,VJ,VJM,VU,VU/A
4	16956-ZM0-000	BRACKET, FUEL COCK	1	-----	-----	1116665 SA/A,SAR/A,SER/A,SJ/A,VA/A,VE/A,VJ/A,VJM/A,VYM
5	17510-ZN4-000	TANK COMP., FUEL	1	-----	-----	SA,SAR,SER,SJ,VA,VC,VC/A,VD,VD/A,VE,VJ,VJM,VU,VU/A
6	17517-ZN4-000	COLLAR, TANK SETTING	2	-----	-----	SA/A,SAR/A,SER/A,SJ/A,VA/A,VE/A,VJ/A,VJM/A,VYM
7	17532-ZM7-000	RUBBER A, TANK MOUNTING	2	-----	-----	SA/A,SAR/A,SER/A,SJ/A,VA/A,VE/A,VJ/A,VJM/A,VYM
8	17620-ZV0-020	CAP ASSY., FUEL TANK	1	-----	-----	SA,SAR,SER,SJ,VA,VC,VC/A,VD,VD/A,VE,VJ,VJM,VU,VU/A
9	17621-ZV0-020	BODY, FUEL CAP	1	-----	-----	SA/A,SAR/A,SER/A,SJ/A,VA/A,VE/A,VJ/A,VJM/A,VYM
10	17622-ZV0-000	INNER, FUEL CAP	1	-----	-----	SA,SAR,SER,SJ,VA,VC,VC/A,VD,VD/A,VE,VJ,VJM,VU,VU/A
11	17623-ZV0-000	SPONGE, FUEL CAP BREATHER ...	1	-----	-----	SA/A,SAR/A,SER/A,SJ/A,VA/A,VE/A,VJ/A,VJM/A,VYM
12	17624-ZV0-000	PACKING, VALVE	1	-----	-----	SA,SAR,SER,SJ,VA,VC,VC/A,VD,VD/A,VE,VJ,VJM,VU,VU/A
13	17625-ZV0-000	PACKING, FUEL CAP	1	-----	-----	SA/A,SAR/A,SER/A,SJ/A,VA/A,VE/A,VJ/A,VJM/A,VYM
14	17626-ZV0-010	VALVE COMP., BREATHER	1	-----	-----	SA,SAR,SER,SJ,VA,VC,VC/A,VD,VD/A,VE,VJ,VJM,VU,VU/A
15	17628-ZV0-000	LINK, FUEL CAP	1	-----	-----	SA/A,SAR/A,SER/A,SJ/A,VA/A,VE/A,VJ/A,VJM/A,VYM
16	17629-ZV0-000	SPRING, FUEL CAP	1	-----	-----	SA,SAR,SER,SJ,VA,VC,VC/A,VD,VD/A,VE,VJ,VJM,VU,VU/A
17	19052-MB4-880	COLLAR, CANISTER MOUNTING ...	2	-----	-----	SA/A,SAR/A,SER/A,SJ/A,VA/A,VE/A,VJ/A,VJM/A,VYM
18	33609-GK4-620	COLLAR, FR. WINKER	1	-----	-----	SA,SAR,SER,SJ,VA,VC,VC/A,VD,VD/A,VE,VJ,VJM,VU,VU/A
19	90015-ZG0-801	BOLT, FLANGE, 6X65	2	-----	-----	SA/A,SAR/A,SER/A,SJ/A,VA/A,VE/A,VJ/A,VJM/A,VYM
20	93891-05010-08	SCREW-WASHER, 5X10	1	-----	-----	SA,SAR,SER,SJ,VA,VC,VC/A,VD,VD/A,VE,VJ,VJM,VU,VU/A
21	94101-04200	WASHER, PLAIN, 4MM	2	-----	-----	SA/A,SAR/A,SER/A,SJ/A,VA/A,VE/A,VJ/A,VJM/A,VYM
22	94103-06800	WASHER, PLAIN, 6MM	2	-----	-----	SA/A,SAR/A,SER/A,SJ/A,VA/A,VE/A,VJ/A,VJM/A,VYM

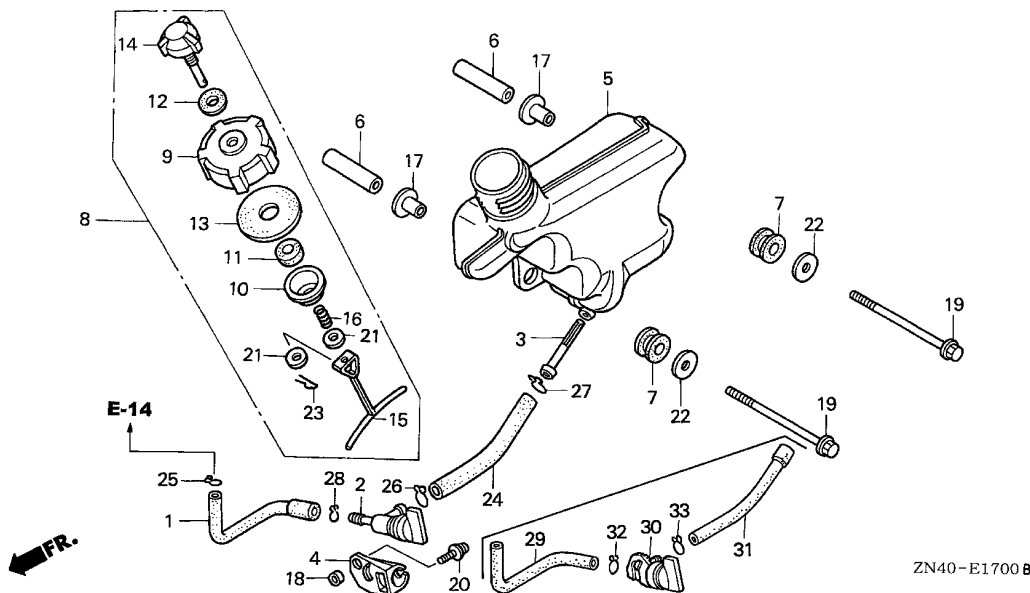

Ref. No.	Part No.	Description	Reqd. QTY		Serial No.	Parts catalogue code
			GXV	50		
23	94251-04000	PIN, LOCK, 4MM	1			
24	95001-75065-40	TUBE, FUEL, 7.5X65 (95001-75001-60M)	1	-----	-----	SA, SAR, SER, SJ, VA, VC, VC/A, VD, VD/A, VE, VJ, VJM, VU, VU/A
			1	-----	1116665	SA/A, SAR/A, SER/A, SJ/A, VA/A, VE/A, VJ/A, VJM/A, VYM
25	95002-02080	CLIP, TUBE (B8)	1			
26	95002-02120	CLIP, TUBE (B12)	1	-----	-----	SA, SAR, SER, SJ, VA, VC, VC/A, VD, VD/A, VE, VJ, VJM, VU, VU/A
			1	-----	1116665	SA/A, SAR/A, SER/A, SJ/A, VA/A, VE/A, VJ/A, VJM/A, VYM
27	95002-02130	CLIP, TUBE (B12.5)	1			
28	95002-50000	CLIP, TUBE (C9)	1	-----	-----	SA, SAR, SER, SJ, VA, VC, VC/A, VD, VD/A, VE, VJ, VJM, VU, VU/A
			1	-----	1116665	SA/A, SAR/A, SER/A, SJ/A, VA/A, VE/A, VJ/A, VJM/A, VYM
29	16861-ZN4-800	TUBE B, FUEL	1	-----	-----	SA/B, SAR/B, SER/B, SJ/B, VA/B, VE/B, VJ/B, VJM/B, VYM/A
			1	1116666	-----	SA/A, SAR/A, SER/A, SJ/A, VA/A, VE/A, VJ/A, VJM/A, VYM
30	16950-ZM0-003	COCK ASSY., FUEL	1	-----	-----	SA/B, SAR/B, SER/B, SJ/B, VA/B, VE/B, VJ/B, VJM/B, VYM/A
			1	1116666	-----	SA/A, SAR/A, SER/A, SJ/A, VA/A, VE/A, VJ/A, VJM/A, VYM
31	17701-ZN4-800	TUBE, FUEL TANK	1	-----	-----	SA/B, SAR/B, SER/B, SJ/B, VA/B, VE/B, VJ/B, VJM/B, VYM/A
			1	1116666	-----	SA/A, SAR/A, SER/A, SJ/A, VA/A, VE/A, VJ/A, VJM/A, VYM
32	95002-02080	CLIP, TUBE (B8)	1	-----	-----	SA/B, SAR/B, SER/B, SJ/B, VA/B, VE/B, VJ/B, VJM/B, VYM/A
			1	1116666	-----	SA/A, SAR/A, SER/A, SJ/A, VA/A, VE/A, VJ/A, VJM/A, VYM
33	95002-02100	CLIP, TUBE (B10)	1	-----	-----	SA/B, SAR/B, SER/B, SJ/B, VA/B, VE/B, VJ/B, VJM/B, VYM/A
			1	1116666	-----	SA/A, SAR/A, SER/A, SJ/A, VA/A, VE/A, VJ/A, VJM/A, VYM



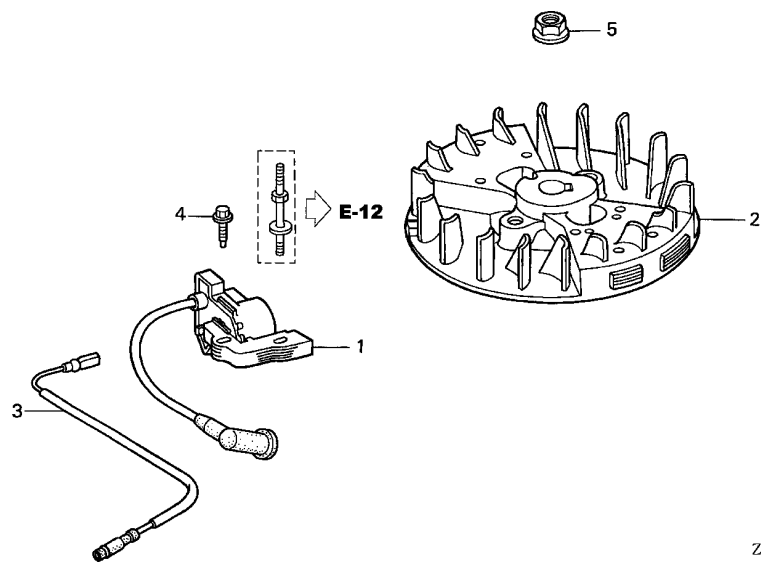

ZN40-E1900 B

Service item

F.R.T.

Ref. No.	Part No.	Description	Reqd. QTY		Serial No.	Parts catalogue code
				GXV 50		
1	30500-ZM7-004	COIL ASSY., IGNITION		1		
2	31110-ZM7-004	FLYWHEEL COMP.		1		
3	32195-ZN4-000	CORD, STOP SWITCH		1		
4	90004-ZC3-000	BOLT, FLANGE, 5X20		1		
5	94050-10000	NUT, FLANGE, 10MM		1		

Service item

F.R.T.

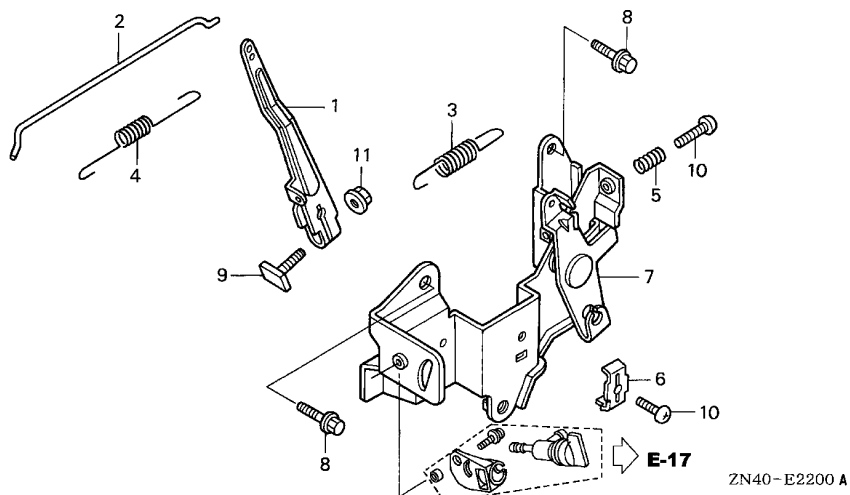

Ref. No.	Part No.	Description	Reqd. QTY		Serial No.	Parts catalogue code
			GXV	50		
1	16551-ZN4-000	ARM, GOVERNOR	1			
2	16555-ZN4-000	ROD, GOVERNOR	1			
3	16561-ZN4-000	SPRING, GOVERNOR	1		SA, SA/A, SA/B, SAR, SAR/A, SAR/B, SER, SER/A, SER/B, SJ, SJ/A, SJ/B, VA, VA/A, VA/B, VC, VC/A, VD, VD/A, VE, VE/A, VE/B, VJ, VJ/A, VJ/B, VU, VU/A, VYM, VYM/A	
	16561-ZN4-U00	1		VJM, VJM/A, VJM/B	
4	16562-ZN4-800	SPRING, THROTTLE RETURN	1		SA, SA/A, SA/B, SAR, SAR/A, SAR/B, SER, SER/A, SER/B, SJ, SJ/A, SJ/B, VA, VA/A, VA/B, VC, VC/A, VD, VD/A, VE, VE/A, VE/B, VJ, VJ/A, VJ/B, VJM, VJM/A, VJM/B, VU, VU/A	
	16562-ZN4-000	1		VYM, VYM/A	
5	16571-892-000	SPRING, CONTROL ADJUSTING	1			
6	16576-891-000	HOLDER, CABLE	1			
7	16580-ZN4-000	BASE COMP., CONTROL	1			
8	90003-892-000	BOLT, FLANGE, 5X12	2			
9	90015-ZE5-010	BOLT, GOVERNOR ARM	1			
10	93500-05020-0H	SCREW, PAN, 5X20	2			
11	94050-06000	NUT, FLANGE, 6MM	1			



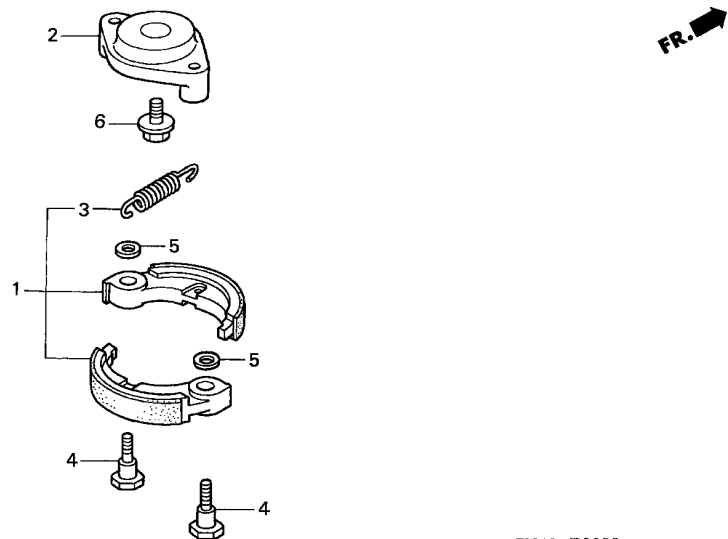

ZN40-E2600

Service item

F.R.T.

2

Ref. No.	Part No.	Description	Reqd. QTY		Serial No.	Parts catalogue code
			GXV	50		
1	22000-ZN4-003	CLUTCH ASSY.	1	-----	-----	VJM,VJM/A,VJM/B,VYM,VYM/A
2	22211-ZN4-000	STAY, CLUTCH	1	-----	-----	VJM,VJM/A,VJM/B,VYM,VYM/A
3	22252-ZN4-003	SPRING, CLUTCH SHOE	1	-----	-----	VJM,VJM/A,VJM/B,VYM,VYM/A
4	22253-ZN4-003	BOLT, CLUTCH (8MM)	2	-----	-----	VJM,VJM/A,VJM/B,VYM,VYM/A
5	22254-ZN4-003	WASHER, CLUTCH (8MM)	2	-----	-----	VJM,VJM/A,VJM/B,VYM,VYM/A
6	22255-ZN4-000	BOLT, CLUTCH STAY (8MM)	1	-----	-----	VJM,VJM/A,VJM/B,VYM,VYM/A

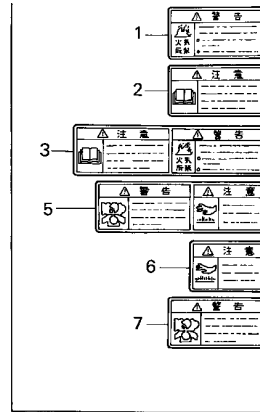
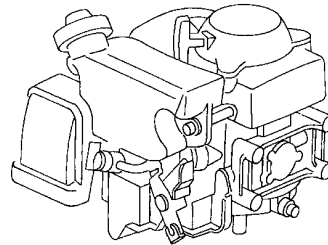
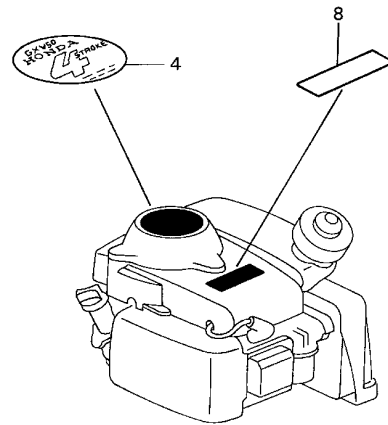

ZN40-E2800

Service item F.R.T.

Ref. No.	Part No.	Description	Reqd. QTY		Serial No.	Parts catalogue code
			GXV	50		
1	87106-737-J00	MARK, FUEL WARNING	(1)	-----	-----	SJ,SJ/A,SJ/B,VJ,VJ/A,VJ/B,VJM,VJM/A,VJM/B,VYM,VYM/A
2	87150-ZH8-000	MARK, CAUTION (JAPANESE)	(1)	-----	-----	SJ,SJ/A,SJ/B,VJ,VJ/A,VJ/B,VJM,VJM/A,VJM/B,VYM,VYM/A
3	87520-ZH8-000	MARK A, COMBINATION	(1)	-----	-----	SJ,SJ/A,SJ/B,VJ,VJ/A,VJ/B,VJM,VJM/A,VJM/B,VYM,VYM/A
4	87521-ZN4-000	EMBLEM	1	-----	-----	SA,SAR,SER,SJ,VA,VC,VC/A,VD,VD/A,VE,VJ,VJM,VU,VU/A
	87521-ZN4-010	1	-----	1111713	SA/A,SAR/A,SER/A,SJ/A,VA/A,VE/A,VJ/A,VJM/A
		1	-----	1111714	SA/B,SAR/B,SER/B,SJ/B,VA/B,VE/B,VJ/B,VJM/B
5	87526-ZH8-000	MARK B, COMBINATION	(1)	-----	-----	SA/A,SAR/A,SER/A,SJ/A,VA/A,VE/A,VJ/A,VJM/A
		(1)	-----	-----	SJ,SJ/A,SJ/B,VJ,VJ/A,VJ/B,VJM,VJM/A,VJM/B,VYM,VYM/A
6	87539-737-J00	MARK, HEAT CAUTION	(1)	-----	-----	SJ,SJ/A,SJ/B,VJ,VJ/A,VJ/B,VJM,VJM/A,VJM/B,VYM,VYM/A
7	87561-733-J00	MARK, EX. GAS WARNING	(1)	-----	-----	SJ,SJ/A,SJ/B,VJ,VJ/A,VJ/B,VJM,VJM/A,VJM/B,VYM,VYM/A
8	87135-ZE2-000	LABEL, E-SPEC (HONDA)	1	-----	-----	SER
		(EPA STANDARD)	1	-----	1025620	SJ,VD,VE,VJ,VJM,VU
	87135-ZE2-010	LABEL, E-SPEC (EPA STANDARD)	1	-----	-----	VD/A,VU/A
	87135-ZE2-020	LABEL, E-SPEC (15.5X27.5) ...	1	-----	-----	SER/A,SER/B,SJ/A,SJ/B,VE/A,VE/B,VJ/A,VJ/B,VJM/A,VJM/B



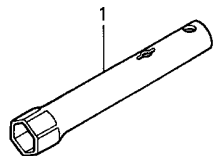

ZN40-E2900

Service item

F.R.T.

Ref. No.	Part No.	Description	Reqd. QTY		Serial No.	Parts catalogue code
			GXV	50		
1	89216-130-690	WRENCH, SPARK PLUG	1	-----	-----	VYM,VYM/A
			(1)	-----	-----	SA,SA/A,SA/B,SAR,SAR/A,SAR/B,SER,SER/A,SER/B,SJ,SJ/A,SJ/B,VA,VA/A,VA/B,VC,VC/A,VD,VD/A,VE,VE/A,VE/B,VJ,VJ/A,VJ/B,VU,VU/A

PART NO. INDEX

E 1

Part Number	Address	Page	Ref.	Part Number	Address	Page	Ref.	Part Number	Address	Page	Ref.	Part Number	Address	Page	Ref.
11000				16000				17623-ZV0-000	C15	26	11	33000			
11300-ZN4-405	C3	14	1	16010-ZG0-015	C11	22	1	17624-ZV0-000	C15	26	12	91503-ZM7-000	C13	24	9
11340-ZN4-010	C4	15	1	16010-ZN4-A01	C11	22	1	17625-ZV0-000	C15	26	13	91504-ZM7-003	C9	20	10
11340-ZN4-020	C4	15	1	16011-ZE0-005	C11	22	2	17626-ZV0-010	C15	26	14	93000			
11340-ZN4-801	C4	15	1	16013-ZG0-811	C11	22	3	17628-ZV0-000	C15	26	15	87000			
11340-ZN4-802	C4	15	1	16015-ZG0-811	C11	22	4	17629-ZV0-000	C15	26	16	87106-737-J00	D4	31	1
				16015-ZG1-D20	C11	22	4	17701-ZN4-800	C16	27	31	87135-ZE2-000	D4	31	8
12000				16016-ZE0-005	C11	22	5	18000				87135-ZE2-010	D4	31	8
12100-ZM7-000	C1	12	1	16016-ZH7-W01	C11	22	6	18310-ZM7-003	C14	25	1	87135-ZE2-020	D4	31	8
12100-ZM7-407	C1	12	1	16024-ZE1-811	C11	22	7	18310-ZM7-801	C14	25	1	87150-ZH8-000	D4	31	2
12100-ZM7-417	C1	12	1	16024-ZH7-A20	C11	22	7	18320-ZM7-000	C14	25	2	87520-ZH8-000	D4	31	3
12209-ZM7-003	C7	18	1	16028-ZG0-811	C11	22	8	18350-ZM7-801	C14	25	3	87521-ZN4-000	D4	31	4
12311-ZM7-000	C1	12	2	16044-ZM7-003	C11	22	9	18515-ZM7-000	C14	25	4	87521-ZN4-010	D4	31	4
12311-ZM7-010	C1	12	2	16100-ZN4-003	C11	22	10	19000				87526-ZH8-000	D4	31	5
12367-ZE6-010	C2	13	16	16100-ZN4-801	C11	22	10	19052-MB4-880	C15	26	17	87539-737-J00	D4	31	6
				16100-ZN4-803	C11	22	10	19610-ZM7-000ZA	C10	21	1	87561-733-J00	D4	31	7
				16100-ZN4-A12	C11	22	10	19610-ZM7-000ZC	C10	21	1	89000			
13000				16124-ZE0-005	C11	22	11	19631-ZM7-000	C1	12	7	89216-130-690	D5	32	1
13010-ZM7-000	C6	17	1	16166-ZM7-003	C12	23	12	22000				90000			
13101-ZM7-000	C6	17	2	16166-ZN4-A01	C12	23	12	22000-ZN4-003	D3	30	1	90001-ZM7-000	C6	17	6
13101-ZM7-010	C6	17	2	16211-ZN4-000	C12	23	13	22211-ZN4-000	D3	30	2	90002-ZM7-000	C14	25	5
13111-122-000	C6	17	3	16212-ZM7-000	C12	23	14	22252-ZN4-003	D3	30	3	90003-892-000	C1	12	8
13115-147-000	C6	17	4	16221-ZG0-801	C12	23	15	22252-ZN4-003	D3	30	3		D2	29	8
13200-ZN4-000	C6	17	5	16225-ZN4-000	C12	23	16	22253-ZN4-003	D3	30	4	90004-ZC3-000	D1	28	4
13310-ZM7-000	C5	16	1	16510-ZM7-000	C4	15	2	22254-ZN4-003	D3	30	5	90004-ZN4-000	C13	24	8
13310-ZN4-000	C5	16	2	16531-ZM7-000	C4	15	3	22255-ZN4-000	D3	30	6	90006-ZM7-000	C3	14	5
13331-ZM7-000	C5	16	3	16541-ZM7-000	C1	12	6	28000					C4	15	4
				16551-ZN4-000	D2	29	1	28400-ZM7-003	C9	20	1	90008-ZM7-000	C1	12	9
				16555-ZN4-000	D2	29	2	28404-968-004	C9	20	12	90012-892-000	C14	25	6
14000				16561-ZN4-000	D2	29	3	28414-ZM7-003	C9	20	2	90012-896-750	C3	14	6
14100-ZM7-000	C7	18	2	16561-ZN4-U00	D2	29	3	28421-ZM7-003	C9	20	3	90012-ZM3-003	C9	20	9
14100-ZM7-010	C7	18	2	16562-ZN4-000	D2	29	4	28433-ZM3-003	C9	20	4	90015-ZE5-010	D2	29	9
14126-Z0G-003	C7	18	3	16562-ZN4-800	D2	29	4	28442-ZL8-003	C9	20	13	90015-ZG0-801	C15	26	19
14410-ZM7-000	C7	18	4	16571-892-000	D2	29	5	28451-ZM7-003	C9	20	5	90042-ZM7-000	C10	21	2
14431-ZM7-000	C7	18	5	16576-891-000	D2	29	6	28459-ZM7-003	C9	20	6	90043-ZM7-000	C10	21	3
14435-ZM7-003	C7	18	6	16580-ZN4-000	D2	29	7	28461-ZM3-003	C9	20	7	90103-P4V-010	C14	25	7
14451-ZM7-000	C7	18	7	16861-ZN4-000	C15	26	1	28462-ZM7-003	C9	20	8	90136-SM4-901	C14	25	8
14711-ZM7-000	C7	18	8	16861-ZN4-800	C16	27	29	30500-ZM7-004	D1	28	1	90206-KM3-000	C7	18	15
14711-ZM7-000	C7	18	8	16950-ZG9-M02	C15	26	2	31110-ZM7-004	D1	28	2	90441-ZM7-000	C4	15	5
14721-ZM7-000	C7	18	9	16950-ZG9-M03	C15	26	2	32000				90443-ZC3-000	C1	12	10
14731-ZM7-003	C7	18	10	16950-ZM0-003	C16	27	30	32195-ZN4-000	D1	28	3	90471-580-000	C4	15	6
14731-ZM7-013	C7	18	10	16952-ZE6-000	C15	26	3					90602-ZM7-000	C4	15	7
14751-ZM7-000	C7	18	11	16956-ZM0-000	C15	26	4					90702-P6R-008	C7	18	3
14754-ZM7-000	C7	18	12									90741-959-000	C5	16	4
14771-ZM3-000	C7	18	13	17000								91000			
14771-ZM3-010	C7	18	13	17211-ZM7-000	C13	24	2	91000				91151-VB5-800	C8	19	16
				17220-ZM7-000	C13	24	3	91202-HC5-003	C3	14	7	91231-ZC3-003	C1	12	11
15000				17227-ZM7-000	C13	24	4					91331-PC9-003	C3	14	8
15171-ZN4-000	C1	12	3	17228-ZM7-000	C13	24	5					91502-ZM3-000	C3	14	9
15361-ZN4-000	C7	18	14	17230-ZM7-000	C13	24	6						C14	25	9
15571-ZM7-003	C1	12	4	17231-ZM7-000	C13	24	7								
15572-ZM7-000	C1	12	5	17510-ZN4-000	C15	26	5								
15600-ZN4-003	C3	14	2	17517-ZN4-000	C15	26	6								
15625-ZE1-003	C3	14	3	17532-ZM7-000	C15	26	7								
15631-ZN4-000	C3	14	4	17620-ZV0-020	C15	26	8								
15721-ZN4-000	C13	24	1	17621-ZV0-020	C15	26	9								
				17622-ZV0-000	C15	26	10								



PART NAME INDEX

F 1

Part name	Address	Page	Ref.	Part name	Address	Page	Ref.	Part name	Address	Page	Ref.
[A]								[L]			
ARM, GOVERNOR	D2	29	1	COLLAR, CANISTER MOUNTING	C15	26	17	LABEL, E-SPEC	D4	31	8
ARM, SWING	C9	20	6	COLLAR, FR. WINKER	C15	26	18	LIFTER, VALVE	C7	18	10
ARM, VALVE ROCKER	C7	18	5	COLLAR, LIFTER	C7	18	12	LINK, FUEL CAP	C15	26	15
ARRESTER COMP., SPARK	C14	25	3	COLLAR, TANK SETTING	C15	26	6				
				COLLAR, TOP COVER	C3	14	9				
					C14	25	9				
[B]				CORD, STOP SWITCH	D1	28	3	[M]			
BARREL COMP., CYLINDER	C1	12	1	COVER COMP., AIR CLEANER	C13	24	6	MARK A, COMBINATION	D4	31	3
BASE COMP., CONTROL	D2	29	7	COVER COMP., CRANKCASE SIDE	C4	15	1	MARK B, COMBINATION	D4	31	5
BODY, FUEL CAP	C15	26	9	COVER COMP., FAN	C10	21	1	MARK, CAUTION	D4	31	2
BOLT-WASHER, 5X16	C8	19	17	COVER, AIR CLEANER	C13	24	7	MARK, EX. GAS WARNING	D4	31	7
BOLT, 4X10	C1	12	9	COVER, HEAD	C1	12	2	MARK, FUEL WARNING	D4	31	1
BOLT, CLUTCH	D3	30	4	CRANKSHAFT COMP.	C5	16	1	MARK, HEAT CAUTION	D4	31	6
BOLT, CLUTCH STAY	D3	30	6					MUFFLER COMP.	C14	25	1
BOLT, CONNECTING ROD	C6	17	6	[D]							
BOLT, FLANGE, 5X12	C1	12	8	DOWEL PIN, 6X10	C4	15	9	[N]			
	D2	29	8					NOZZLE, MAIN	C12	23	12
BOLT, FLANGE, 5X14	C3	14	6	[E]				NUT, FLANGE, 10MM	D1	28	5
BOLT, FLANGE, 5X16	C14	25	6	ELEMENT, AIR CLEANER	C13	24	2	NUT, FLANGE, 5MM	C9	20	11
BOLT, FLANGE, 5X20	D1	28	4	EMBLEM	D4	31	4	NUT, FLANGE, 6MM	D2	29	11
BOLT, FLANGE, 5X23	C3	14	5	EXTENSION, OIL FILLER	C3	14	4	NUT, SELF-LOCK, 5MM	C14	25	8
	C4	15	4					NUT, TAPPET ADJUSTING	C7	18	15
BOLT, FLANGE, 5X35	C14	25	7	[F]							
BOLT, FLANGE, 5X65	C13	24	8	FILTER, BREATHER	C2	13	16	[O]			
BOLT, FLANGE, 6X65	C15	26	19	FLOAT SET	C11	22	3	OIL SEAL, 17X27X5	C3	14	7
BOLT, FLANGE, 8X12	C4	15	10	FLYWHEEL COMP.	D1	28	2	OIL SEAL, 5X11X5	C1	12	11
BOLT, GOVERNOR ARM	D2	29	9					O-RING, 21.2X2.4	C3	14	8
BOLT, STUD	C10	21	2	[G]							
			3	GASKET SET	C11	22	1	[P]			
BOLT, STUD, 2,5X55	C14	25	5	GOVERNOR ASSY.	C4	15	2	PACKING, 8MM	C4	15	6
BRACKET, FUEL COCK	C15	26	4	GUIDE, AIR	C14	25	4	PACKING, AIR CLEANER	C13	24	5
				GUIDE, ROPE	C9	20	4	PACKING, CARBURETOR	C12	23	15
[C]								PACKING, FUEL CAP	C15	26	13
CAMSHAFT ASSY.	C7	18	2	[H]				PACKING, INSULATOR	C12	23	14
CAP ASSY., FUEL TANK	C15	26	8	HOLDER, CABLE	D2	29	6	PACKING, OIL FILLER CAP	C3	14	3
CAP ASSY., OIL FILLER	C3	14	2					PACKING, VALVE	C15	26	12
CARBURETOR ASSY.	C11	22	10	[I]				PIN, LOCK, 4MM	C16	27	23
CASE ASSY., OIL	C3	14	1	INNER, FUEL CAP	C15	26	10	PIN, LOCK, 6MM	C1	12	13
CASE COMP., AIR CLEANER	C13	24	3	INSULATOR, CARBURETOR	C12	23	13	PIN, OIL PUMP	C7	18	3
CASE, RECOIL STARTER	C9	20	2					PIN, PISTON, 10X33	C6	17	3
CHAMBER SET, FLOAT	C11	22	4	[J]				PIPE, BREATHER	C1	12	3
CHOKE SET	C11	22	9	JET SET, PILOT,	C12	23	19	PISTON	C6	17	2
CLIP, GOVERNOR HOLDER	C4	15	7	JET, MAIN,	C12	23	18	PIVOT, ROCKER ARM	C7	18	7
CLIP, PISTON PIN, 10MM	C6	17	4					PLATE, CARBURETOR JOINT	C12	23	16
CLIP, TUBE	C16	27	25	[K]				PLATE, STOPPER	C1	12	5
			26	KEY, 5MM	C5	16	4	PLUG, SPARK	C1	12	15
			27	KEY, SPECIAL	C5	16	3		C2	13	15
			28	KNOB, RECOIL STARTER	C9	20	7	PROTECTOR COMP., MUFFLER	C14	25	2
			32					PULLEY, RECOIL STARTER	C9	20	5
			33					[R]			
CLUTCH ASSY.	D3	30	1					REEL, RECOIL STARTER	C9	20	3
COCK ASSY., FUEL	C15	26	2					RETAINER, VALVE SPRING	C7	18	13
	C16	27	30								
COIL ASSY., IGNITION	D1	28	1								
COLLAR	C9	20	10								
COLLAR, AIR CLEANER	C13	24	9								

PART NAME INDEX

F 2

Part name	Address	Page	Ref.	Part name	Address	Page	Ref.	Part name	Address	Page	Ref.
RING SET, PISTON	C6	17	1								
ROD ASSY., CONNECTING	C6	17	5								
ROD, GOVERNOR	D2	29	2								
ROD, PUSH	C7	18	4								
ROLLER	C7	18	3								
			6								
ROLLER, 6X15	C1	12	14								
ROLLER, 6X25	C8	19	16								
ROPE, RECOIL STARTER	C9	20	8								
RUBBER A, TANK MOUNTING	C15	26	7								
[S]											
SCREW-WASHER, 5X10	C15	26	20								
SCREW SET	C11	22	8								
SCREW SET, DRAIN	C11	22	7								
SCREW SET, PILOT	C11	22	5								
			6								
SCREW, FLAT, 5X20	C12	23	17								
SCREW, PAN, 3X5	C1	12	12								
SCREW, PAN, 5X20	D2	29	10								
SCREW, SETTING	C9	20	9								
SCREW, TAPPING, 4X8	C14	25	10								
SCREW, THROTTLE STOP	C11	22	11								
SEAL, AIR CLEANER	C13	24	4								
SEAL, VALVE STEM	C7	18	1								
SHAFT, GOVERNOR ARM	C1	12	6								
SHROUD	C1	12	7								
SLIDER, GOVERNOR	C4	15	3								
SLINGER, OIL	C7	18	14								
SPONGE, FUEL CAP BREATHER	C15	26	11								
SPRING, CLUTCH SHOE	D3	30	3								
SPRING, CONTROL ADJUSTING	D2	29	5								
SPRING, FRICTION	C9	20	12								
SPRING, FUEL CAP	C15	26	16								
SPRING, GOVERNOR	D2	29	3								
SPRING, RECOIL STARTER	C9	20	13								
SPRING, THROTTLE RETURN	D2	29	4								
SPRING, VALVE	C7	18	11								
STARTER ASSY., RECOIL	C9	20	1								
STAY, CLUTCH	D3	30	2								
STRAINER, FUEL	C15	26	3								
[T]											
TANK COMP., FUEL	C15	26	5								
TUBE B, FUEL	C15	26	1								
	C16	27	29								
TUBE, BREATHER	C13	24	1								
TUBE, FUEL TANK	C16	27	31								
TUBE, FUEL, 7.5X65	C16	27	24								
[V]											
VALVE COMP., BREATHER	C15	26	14								
VALVE SET, FLOAT	C11	22	2								
VALVE, EX.	C7	18	9								
VALVE, IN.	C7	18	8								
VALVE, OIL OUTLET	C1	12	4								

1

FOREWORD INDEX

2

ENGINE GROUP

3

PART NUMBER INDEX

4

PART NAME INDEX

HONDA
The Power of Dreams

October 03, 2004



PARTS CATALOG NEWS

Honda Motor Co., Ltd. Service Division

PARTS CATALOG - CORRECTED

Printed in Japan

CODE NO.	14ZN40E5
PARTS CATALOG NEWS	GXV50
NEWS NO.	001

Block No.	Ref. No.	Note	Part No.	Description	Reqd. QTY	Serial No.	Parts catalog code
					GXV 50		
E-14	1	L	16010-ZG0-015	GASKET SET (CARBURETOR NO.)	1	----- BF31D C	SA/B, SAR/B, SER/B, SJ/B, VA/B, VE/B, VJ/B, VJM/B
		D	16010-ZG2-D10 (CARBURETOR NO.)	1	BF31D D -----	SA/B, SAR/B, SER/B, SJ/B, VA/B, VE/B, VJ/B, VJM/B
	12	L	16166-ZM7-003	NOZZLE, MAIN (CARBURETOR NO.)	1	----- BF31D C	SA/B, SAR/B, SER/B, SJ/B, VA/B, VE/B, VJ/B, VJM/B
		D	16166-ZN4-801 (CARBURETOR NO.)	1	BF31D D -----	SA/B, SAR/B, SER/B, SJ/B, VA/B, VE/B, VJ/B, VJM/B
	18	D	99101-ZG0-0480	JET, MAIN, #48 (CARBURETOR NO.)	(1)	BF31D D -----	SA/B, SAR/B, SER/B, SJ/B, VA/B, VE/B, VJ/B, VJM/B
			L	99101-ZG0-0520	JET, MAIN, #52 (CARBURETOR NO.)	(1)	----- BF31D C
		L	99101-ZG0-0550	JET, MAIN, #55 (CARBURETOR NO.)	1	----- BF31D C	SA/B, SAR/B, SER/B, SJ/B, VA/B, VE/B, VJ/B, VJM/B
		D	99101-ZG0-0520	JET, MAIN, #52 (CARBURETOR NO.)	1	BF31D D -----	SA/B, SAR/B, SER/B, SJ/B, VA/B, VE/B, VJ/B, VJM/B

NOTE A:PART NO. CHANGE D:NEWLY PROVIDED E:PART NO.DELETION K:REQUIRED NO. CORRECTION L:APPLICATION SERIAL NO. CORRECTION
T:APPLICATION CORRECTION Z:REMARKS CHANGE

October 24, 2004



PARTS CATALOG NEWS

Honda Motor Co., Ltd. Service Division

PARTS CATALOG - CORRECTED

Printed in Japan

CODE NO.	14ZN40E5
PARTS CATALOG NEWS	GXV50
NEWS NO.	002

Block No.	Ref. No.	Note	Part No.	Description	Reqd. QTY	Serial No.	Parts catalog code
					GXV 50		
E-14	10	L	16100-ZN4-803	CARBURETOR ASSY. (BF31D C) ...	1	----- 1213340	SA/B, SAR/B, SER/B, SJ/B, VA/B, VE/B, VJ/B, VJM/B
		D	16100-ZN4-804	CARBURETOR ASSY. (BF31D D) ...	1	1213341 -----	SA/B, SAR/B, SER/B, SJ/B, VA/B, VE/B, VJ/B, VJM/B

NOTE A:PART NO. CHANGE D:NEWLY PROVIDED E:PART NO.DELETION K:REQUIRED NO. CORRECTION L:APPLICATION SERIAL NO. CORRECTION
T:APPLICATION CORRECTION Z:REMARKS CHANGE

November 21, 2004



PARTS CATALOG NEWS

Honda Motor Co., Ltd. Service Division

PARTS CATALOG - CORRECTED

Printed in Japan

CODE NO.	14ZN40E5
PARTS CATALOG NEWS	GXV50
NEWS NO.	003

Block No.	Ref. No.	Note	Part No.	Description	Reqd. QTY	Serial No.	Parts catalog code
					<small>GXV 50</small>		
E-3	16	T	12367-ZE6-010	FILTER, BREATHER	1	1212463 -----	SA/B, SAR/B, SER/B, SJ/B, VA/B, VE/B, VJ/B
E-28	8	L	87135-ZE2-020	LABEL, E-SPEC (15.5X27.5)	1	----- 1212462	SER/B, VE/B

NOTE A:PART NO. CHANGE D:NEWLY PROVIDED E:PART NO.DELETION K:REQUIRED NO. CORRECTION L:APPLICATION SERIAL NO. CORRECTION
T:APPLICATION CORRECTION Z:REMARKS CHANGE

June 27, 2005



PARTS CATALOG NEWS

Honda Motor Co., Ltd. Service Division

PARTS CATALOG - CORRECTED

Printed in Japan

CODE NO.	14ZN40E5
PARTS CATALOG TITLE	GXV50
NEWS NO.	004

Block No.	Ref. No.	Note	Part No.	Description	Reqd. QTY	Serial No.	Parts catalog code
E-28					GXV 50		

E-28 LABEL

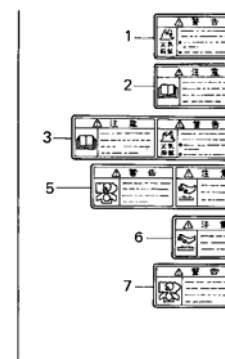
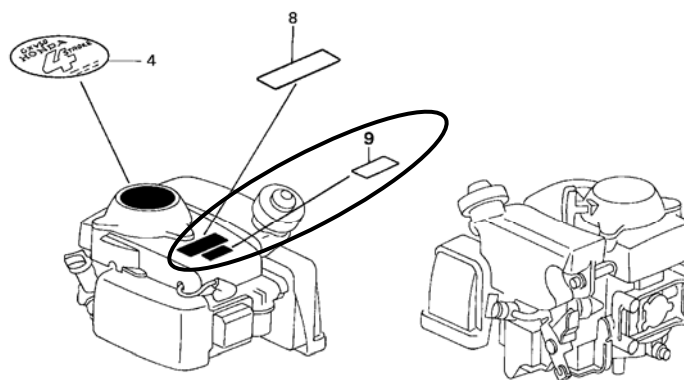

ZN40-E2800A

E-28	9	D	87114-ZH7-000	LABEL, WARNING (NOT CERTIFIED FOR SALE)	1	1222373	SJ/B, VJ/B, VJM/B
------	---	---	---------------	--	---	---------	-------------------

NOTE A:PART NO. CHANGE D:NEWLY PROVIDED E:PART NO.DELETION K:REQUIRED NO. CORRECTION L:APPLICATION SERIAL NO. CORRECTION
T:APPLICATION CORRECTION Z:REMARKS CHANGE

January 29, 2006



PARTS CATALOG NEWS

Honda Motor Co., Ltd. Service Division

PARTS CATALOG - CORRECTED

Printed in Japan

CODE NO.	14ZN40E5
PARTS CATALOG TITLE	GXV50
NEWS NO.	005

Block No.	Ref. No.	Note	Part No.	Description	Reqd. QTY	Serial No.	Parts catalog code
E-28	8	L	87135-ZE2-020	LABEL, E-SPEC (15.5X27.5)	1	----- 1229656	SJ/B, VJ/B, VJM/B

NOTE A:PART NO. CHANGE D:NEWLY PROVIDED E:PART NO.DELETION K:REQUIRED NO. CORRECTION L:APPLICATION SERIAL NO. CORRECTION
T:APPLICATION CORRECTION Z:REMARKS CHANGE



PARTS CATALOG NEWS

Honda Motor Co., Ltd. Service Division

PARTS CATALOG - CORRECTED

Printed in Japan

CODE NO.	14ZN40E5
PARTS CATALOG TITLE	GXV50
NEWS NO.	006

Block No.	Ref. No.	Note	Part No.	Description	Reqd. QTY	Serial No.	Parts catalog code
					GXV 50		

E-14 CARBURETOR

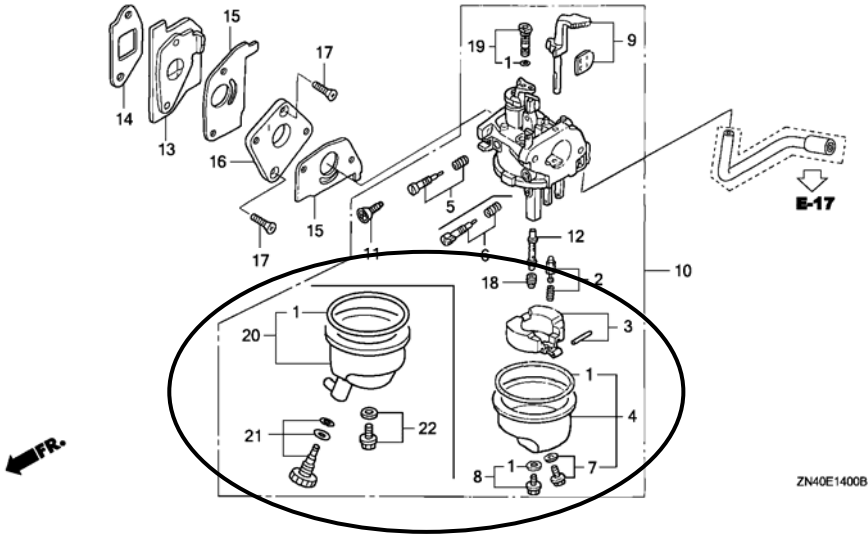

ZN40E1400B

E-14	4	E	16015-ZG1-D20	*PARTS NO. DELETION			
	7	E	16024-ZH7-A20	*PARTS NO. DELETION			

NOTE A:PART NO. CHANGE D:NEWLY PROVIDED E:PART NO.DELETION K:REQUIRED NO. CORRECTION L:APPLICATION SERIAL NO. CORRECTION
T:APPLICATION CORRECTION Z:REMARKS CHANGE

PARTS CATALOG NEWS

BOOKNo. : 14ZN40E5

Block No.	Ref. No.	Note	Part No.	Description	Reqd. QTY	Serial No.		Parts catalog code
					GXV 50			
	20	D	16015-ZG1-D20	CHAMBER SET, FLOAT	1	-----	-----	VYM, VYM/A
	21	D	16024-ZH7-A20	SCREW SET, DRAIN	1	-----	-----	VYM, VYM/A
	22	D	16028-ZG0-811	SCREW SET	1	-----	-----	VYM, VYM/A

NOTE A:PART NO. CHANGE D:NEWLY PROVIDED E:PART NO.DELETION K:REQUIRED NO. CORRECTION L:APPLICATION SERIAL NO. CORRECTION
T:APPLICATION CORRECTION Z:REMARKS CHANGE

May 27, 2007



PARTS CATALOG NEWS

Honda Motor Co., Ltd. Service Division

PARTS CATALOG - CORRECTED

Printed in Japan

CODE NO.	14ZN40E5
PARTS CATALOG NEWS	GXV50
NEWS NO.	007

Block No.	Ref. No.	Note	Part No.	Description	Reqd. QTY	Serial No.	Parts catalog code
					GXV 50		
E-19	1	L	30500-ZM7-004	COIL ASSY., IGNITION	1	----- 1250966	SJ/B, VJ/B, VJM/B, VYM/A
		D	30500-ZM7-014	1	1250967 -----	SJ/B, VJ/B, VJM/B, VYM/A

NOTE A:PART NO. CHANGE D:NEWLY PROVIDED E:PART NO.DELETION K:REQUIRED NO. CORRECTION L:APPLICATION SERIAL NO. CORRECTION
T:APPLICATION CORRECTION Z:REMARKS CHANGE

June 24, 2007



PARTS CATALOG NEWS

Honda Motor Co., Ltd. Service Division

PARTS CATALOG - CORRECTED

Printed in Japan

CODE NO.	14ZN40E5
PARTS CATALOG NEWS	GXV50
NEWS NO.	008

Block No.	Ref. No.	Note	Part No.	Description	Reqd. QTY	Serial No.	Parts catalog code
					GXV 50		

E-28 LABEL

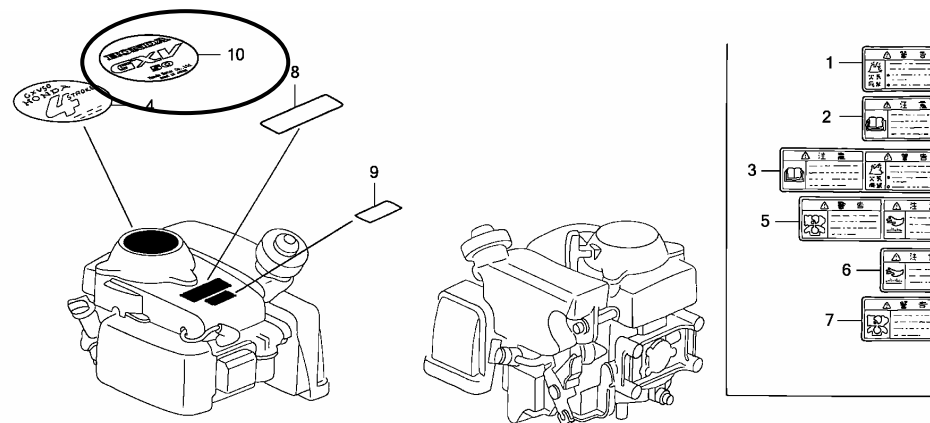

ZN40E2800B

E-28	4	L	87521-ZN4-010	EMBLEM (4STROKE)	1	----- 1247423	SJ/B, VJ/B, VJM/B
	10	D	87521-ZN4-020	EMBLEM (GXV50)	1	1247424 -----	SJ/B, VJ/B, VJM/B

NOTE A:PART NO. CHANGE D:NEWLY PROVIDED E:PART NO.DELETION K:REQUIRED NO. CORRECTION L:APPLICATION SERIAL NO. CORRECTION
T:APPLICATION CORRECTION Z:REMARKS CHANGE

January 01, 2009



PARTS CATALOG NEWS

Honda Motor Co., Ltd. Service Division

PARTS CATALOG - CORRECTED

Printed in Japan

CODE NO.	14ZN40E5
PARTS CATALOG NEWS	GXV50
NEWS NO.	009

Block No.	Ref. No.	Note	Part No.	Description	Reqd. QTY	Serial No.	Parts catalog code
					GXV 50		
E-17	8	L	17620-ZV0-020	CAP ASSY., FUEL TANK	1	----- 1280622	SJ/B, VJ/B, VJM/B, VYM/A
		D	17620-ZV0-040	1	1280623 -----	SJ/B, VJ/B, VJM/B, VYM/A
	9	L	17621-ZV0-020	BODY, FUEL CAP	1	----- 1280622	SJ/B, VJ/B, VJM/B, VYM/A
		D	17621-ZV0-030	1	1280623 -----	SJ/B, VJ/B, VJM/B, VYM/A

NOTE A:PART NO. CHANGE D:NEWLY PROVIDED E:PART NO.DELETION K:REQUIRED NO. CORRECTION L:APPLICATION SERIAL NO. CORRECTION
T:APPLICATION CORRECTION Z:REMARKS CHANGE



PARTS CATALOG NEWS

Honda Motor Co., Ltd. Service Division

PARTS CATALOG - CORRECTED

Printed in Japan

CODE NO.	14ZN40E5
PARTS CATALOG NEWS	GXV50
NEWS NO.	010

Block No.	Ref. No.	Note	Part No.	Description	Reqd. QTY	Serial No.	Parts catalog code
					GXV 50		

E-17 FUEL TANK

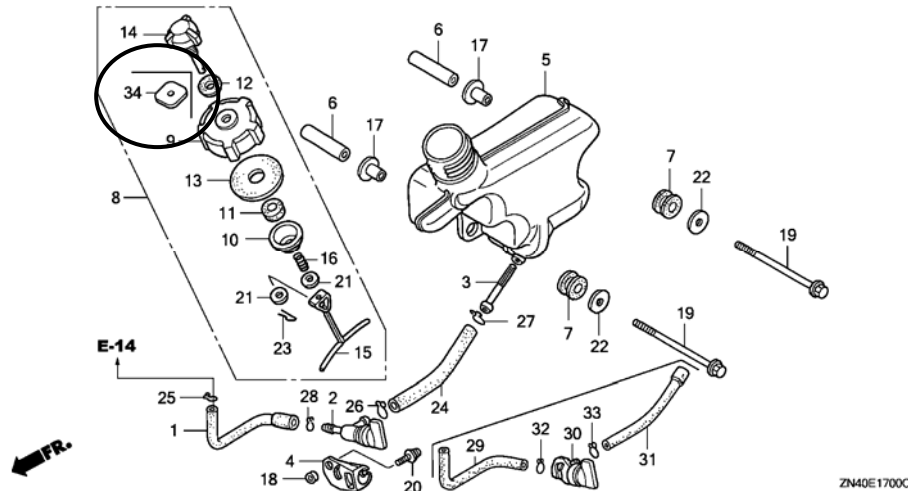

E-17	8	L	17620-ZV0-020	CAP ASSY., FUEL TANK	1	----- 1277928	SJ/B, VJ/B, VJM/B, VYM/A
		D	17620-ZV0-030	1	1277929 -----	SJ/B, VJ/B, VJM/B, VYM/A

NOTE A:PART NO. CHANGE D:NEWLY PROVIDED E:PART NO.DELETION K:REQUIRED NO. CORRECTION L:APPLICATION SERIAL NO. CORRECTION
T:APPLICATION CORRECTION Z:REMARKS CHANGE

PARTS CATALOG NEWS

BOOKNo. : 14ZN40E5

Block No.	Ref. No.	Note	Part No.	Description	Reqd. QTY	Serial No.		Parts catalog code
					GXV 50			
	12	L	17624-ZV0-000	PACKING, VALVE	1	-----	1277928	SJ/B, VJ/B, VJM/B, VYM/A
	14	L	17626-ZV0-010	VALVE COMP., BREATHER	1	-----	1277928	SJ/B, VJ/B, VJM/B, VYM/A
		D	17626-ZV0-020	1	1277929	-----	SJ/B, VJ/B, VJM/B, VYM/A
	34	D	17624-ZN4-000	PACKING, VALVE	1	1277929	-----	SJ/B, VJ/B, VJM/B, VYM/A

NOTE A:PART NO. CHANGE D:NEWLY PROVIDED E:PART NO.DELETION K:REQUIRED NO. CORRECTION L:APPLICATION SERIAL NO. CORRECTION
T:APPLICATION CORRECTION Z:REMARKS CHANGE